



DBV™ Series

DBV-400 Banknote Validator

Operation and Maintenance Manual

(Revision 1)



REVISION HISTORY		
Rev No.	Date	Reason for Update
A	1-9-15	Initial Document
1	6-10-16	Added the Rear Access Cash Box and Snack Mask (Green) Bezel specifications in Section 1 and Section 2, updated Technical Contact Information in Section 1 and Section 3, updated Performance Test Procedures in Section 6, EDP numbers in Section 7, and updated Reject Codes in Appendix A.
	Oct. 29, 2021	Redesigned the cover and added the UKCA mark to the International Compliance. Updated the technical contact information in Section 1 and Section 3. Updated EDP numbers in Section 7.

International Compliance

- RoHS Directive  or  or  or  or 
- UL & c-UL Marks  File No. E142330
- CE Mark 
- UKCA Mark 
- CB Scheme JP-12044-UL
- FCC Directive

This device complies with part 15 of the FCC Rules. Operation is subject to the following two conditions:

- (1) This device may not cause harmful interference, and
- (2) this device must accept any interference received, including interference that may cause undesired operation.

FCC CAUTION

Changes or modifications not expressly approved by the party responsible for compliance could void the user's authority to operate the equipment.

Note: This equipment has been tested and found to comply with the limits for a Class B digital device, pursuant to part 15 of the FCC Rules. These limits are designed to provide reasonable protection against harmful interference in a residential installation. This equipment generates, uses and can radiate radio frequency energy and, if not installed and used in accordance with the instructions, may cause harmful interference to radio communications. However, there is no guarantee that interference will not occur in a particular installation. If this equipment does cause harmful interference to radio or television reception, which can be determined by turning the equipment off and on, the user is encouraged to try to correct the interference by one or more of the following measures:

- Reorient or relocate the receiving antenna.
- Increase the separation between the equipment and receiver.
- Connect the equipment into an outlet on a circuit different from that to which the receiver is connected.
- Consult the dealer or an experienced radio/TV technician for help.

Electrical Current Symbol

Direct Current:  indicates Direct Current values on product labels.

The JCM Website for patents is: <http://www.jcm-hq.co.jp/english/patents/>

Copyright © 2021 By JAPAN CASH MACHINE CO., LTD.

This product document (hereinafter referred to as "Manual") is fully covered by legal Copyrights owned by the JAPAN CASH MACHINE CO., LTD. (hereinafter referred to as "JCM") under Japanese laws and other Foreign Countries. This Manual contains many copyrighted, patented or properly registered equipment items manufactured by JCM, that are prohibited and illegal to duplicate, replicate, copy in whole, or in part, without the express authorization by JCM with the following exceptions:

1. When an authorized JCM agency or distributor duplicates the Manual for sales promotion and/or service maintenance of the product, or technical service personnel education as required; and
2. When an end user duplicates the Manual to maintain operation of the product or operate the product in general.

JCM retains all rights to amend, alter, change or delete any portion of this Manual in whole, or in part, or add items thereto without notice regarding the product or its related products. JCM is a registered trademark of JAPAN CASH MACHINE CO., LTD. All other product names mentioned herein may be registered trademarks or trademarks of their respective companies. Furthermore, ™, ® and © are not always mentioned in each case throughout this publication.

DBV™ Series

DBV-400 Banknote Validator

Table of Contents

	Page
1 GENERAL INFORMATION	1-1
DBV-400 Unit (SU and SD Models)	1-1
Product Descriptions	1-2
Model Descriptions	1-2
Type Descriptions	1-2
Software Descriptions.....	1-2
Precautions	1-2
User Cautions	1-2
Installation Cautions	1-2
Mounting, Dismounting & Transportation	1-3
Placing Foreign Objects into the Unit	1-3
Preventive Maintenance	1-3
Banknote Fitness Requirements	1-3
Primary Features	1-4
Component Names	1-5
Specifications	1-6
Technical Specifications	1-6
Environmental Specifications	1-7
Electrical Specifications.....	1-7
Structural Specifications	1-7
Unit Dimensions	1-8
Entire Unit Outside Dimensions.....	1-8
Entire Unit Outside Dimensions (Continued).....	1-9
Entire Unit Outside Dimensions (Continued).....	1-10
Technical Contact Information	1-11
Americas.....	1-11
JCM American	1-11
Europe, Middle East, Africa & Russia	1-11
JCM Europe GmbH	1-11
UK & Ireland	1-11
JCM Europe (UK Office).....	1-11
Asia and Oceania	1-11
JCM American (Australia Office)	1-11
JAPAN CASH MACHINE CO., LTD. (HQ).....	1-11
2 INSTALLATION	2-1
Installation Procedure	2-1
Entire Unit Installation.....	2-1
DIP Switch Configurations	2-1
DIP Switch Block 1	2-1
DIP Switch Block 2	2-1
Bezel LED Default Color Settings.....	2-2
Connector Pin Assignments	2-3
MDB/Photo-Coupler Isolation Connector Pin Assignments.....	2-3

Table of Contents

	Page
RS232 Connector Pin Assignments	2-4
TTL Connector Pin Assignments	2-5
ID-002 Pulse Connector Pin Assignments	2-6
ID-044 Pulse Connector Pin Assignments	2-7
ID-044 Serial Connector Pin Assignments	2-8
USB Interface Connector Pin Assignments	2-9
USB Maintenance Interface Connector Pin Assignment	2-9
Preventive Maintenance	2-10
Retrieving Banknotes	2-10
Clearing a Banknote Jam	2-10
Cleaning Procedure	2-11
Sensor and Roller Cleaning Procedure	2-11
Sensor and Roller Locations	2-12
Standard Interface Circuit Schematics	2-13
Standard Interface Circuit Schematics (Continued 1)	2-14
Standard Interface Circuit Schematics (Continued 2)	2-15
Standard Interface Circuit Schematics (Continued 3)	2-16
Standard Interface Circuit Schematics (Continued 4)	2-17
Standard Interface Circuit Schematics (Continued 5)	2-18
Standard Interface Circuit Schematics (Continued 6)	2-19
Operational Flowchart	2-21
Operational Flowchart (Continued 1)	2-22
3 COMMUNICATIONS	3-1
Americas	3-1
JCM American	3-1
Europe, Middle East, Africa & Russia	3-1
JCM Europe GmbH	3-1
UK & Ireland	3-1
JCM Europe (UK Office)	3-1
Asia and Oceania	3-1
JCM American (Australia Office)	3-1
JAPAN CASH MACHINE CO., LTD. (HQ)	3-1
4 DISASSEMBLY/REASSEMBLY	4-1
Tool Requirements	4-1
CPU Circuit Board Removal	4-1
Side Sensor Removal	4-2
Motor Harness Assy. Removal	4-2
Inside Validation Sensor Board Removal	4-2
Outside Validation Sensor Board Removal	4-3
Box Base Assy. Removal	4-4
5 WIRING DIAGRAMS	5-1
System Wiring Diagram	5-1
6 CALIBRATION AND TESTING	6-1
Tool Requirement	6-1

Table of Contents

	Page
With Reference Paper and a PC	6-1
Without a PC	6-1
Power Supply	6-1
Installation Procedures	6-1
Application Software Installation.....	6-1
Driver Installation Procedure	6-3
JCM Tool Suite Standard Edition Mode	6-3
Download Procedures	6-3
Software Program Download.....	6-4
Calibration	6-5
When to Calibrate.....	6-5
Placing the KS-095A Reference Paper	6-5
Calibration Preparation.....	6-8
Sensor Calibration	6-8
Performance Tests	6-11
Performance Test Using a PC	6-11
Performance Test Preparation.....	6-11
Feed Motor Test	6-12
Stacking Test	6-12
Sensor Test	6-13
DIP Switch Test	6-14
Bezel LED Test.....	6-14
Performance Test Without a PC	6-15
Aging Test.....	6-15
Acceptance Test.....	6-16
Sensor Test	6-16
Push Button Test	6-17
DIP Switch Test	6-17
Other Performance Tests	6-18
7 EXPLODED VIEWS AND PARTS LISTS	7-1
Entire DBV-400 Unit Exploded View	7-1
Entire DBV-400 Unit	7-2
DBV-400 Main Unit Exploded View 1	7-3
DBV-400 Main Unit Parts List 1	7-4
DBV-400 Main Unit Exploded View 2	7-5
DBV-400 Main Unit Parts List 2	7-6
DBV-400 Validation Guide Cover Assy. Exploded View	7-7
DBV-400 Validation Guide Cover Assy. Parts List	7-7
DBV-400 Validation Guide Exploded View	7-8
DBV-400 Validation Guide Parts List	7-9
DBV-400 Cash Box Exploded View	7-10
DBV-400 Cash Box Parts List.....	7-11
DBV-400 Bezel Unit Exploded View	7-13
DBV-400 Bezel Unit Parts List.....	7-13
8 INDEX	8-1

Table of Contents

	Page
A TROUBLESHOOTING	A-1
Introduction	A-1
Troubleshooting Overview	A-1
Fault Table Listings	A-1
Adjustment Error	A-2
Communication Error	A-3
LED Indication Conditions	A-3
LED Flash Error Code Conditions	A-3
LED Flash Reject Code Conditions	A-6
Maintenance Equipment	A-8
DBV-400 Maintenance Equipment	A-8
Reference Paper Handling	A-9
B GLOSSARY	B-1

DBV™ Series

DBV-400 Banknote Validator

List of Figures

		Page
Figure 1-1	DBV-400 Unit	1-1
Figure 1-2	Precautionary Symbols	1-2
Figure 1-3	Unacceptable Banknotes	1-3
Figure 1-4	DBV-400 Component Names	1-5
Figure 1-5	DBV-400 Unit With JCM Standard Bezel Outside Dimensions	1-8
Figure 1-6	DBV-400 Unit With Snack Mask Bezel Outside Dimensions	1-8
Figure 1-7	DBV-400 Unit With TOB Type Bezel Outside Dimensions	1-9
Figure 1-8	DBV-400 Unit With Euro Type Bezel Outside Dimensions	1-9
Figure 1-9	DBV-400 Unit With Compatible Type Bezel Outside Dimensions .	1-10
Figure 2-1	Threaded Studs Location	2-1
Figure 2-2	Bezel LED Color DIP SW1 Settings	2-2
Figure 2-3	Retrieving Banknotes 1 (Standard Cash Box)	2-10
Figure 2-4	Retrieving Banknotes 1 (Rear-Access Cash Box)	2-10
Figure 2-5	Retrieving Banknotes 2	2-10
Figure 2-6	Clearing a Banknote Jam 1	2-10
Figure 2-7	Clearing a Banknote Jam 2	2-10
Figure 2-8	Clearing a Banknote Jam 3	2-10
Figure 2-9	General Cleaning Image	2-11
Figure 2-10	DBV-400 Sensor and Roller Cleaning Locations	2-12
Figure 2-11	DBV-400 ID-003/MDB Photo-Coupler Isolation Interface Schematic Diagram	2-13
Figure 2-12	DBV-400 ID-003 RS232C Interface Schematic Diagram	2-14
Figure 2-13	DBV-400 ID-003 TTL Interface Schematic Diagram	2-15
Figure 2-14	DBV-400 ID-002 Pulse Interface Schematic Diagram	2-16
Figure 2-15	DBV-400 ID-044 Pulse Interface Schematic Diagram	2-17
Figure 2-16	DBV-400 ID-044 Serial Interface Schematic Diagram	2-18
Figure 2-17	DBV-400 USB Interface Schematic Diagram	2-19
Figure 2-18	DBV-400 Operational Flowchart (Initializing)	2-21
Figure 2-19	DBV-400 Operational Flowchart (Validation)	2-22
Figure 2-20	DBV-400 Operational Flowchart (Stacking)	2-22
Figure 4-1	Cash Box Removal	4-1
Figure 4-2	Bezel Unit Removal	4-1
Figure 4-3	Unplugging Connector	4-1
Figure 4-4	Main Frame Assy. Removal	4-1
Figure 4-5	Unplugging Connector	4-2
Figure 4-6	CPU Circuit Board Removal	4-2

List of Figures

	Page
Figure 4-7	Side Sensor Removal 4-2
Figure 4-8	Motor Harness Assy. Removal 4-2
Figure 4-9	Validation Guide Removal 4-2
Figure 4-10	Validation Guide Removal 4-3
Figure 4-11	Inside Validation Sensor Board Removal 4-3
Figure 4-12	Outside Guide Cover Removal 4-3
Figure 4-13	Outside Validation Sensor Board Removal 4-3
Figure 4-14	Box Base Assy. Removal 1 4-4
Figure 4-15	Box Base Assy. Removal 2 4-4
Figure 5-1	DBV-400 System Wiring Diagram 5-1
Figure 6-1	Tool and Harness Connections 1 6-1
Figure 6-2	USB Cable Type Requirement 6-1
Figure 6-3	Tool and Harness Connections 2 6-1
Figure 6-4	Setup.exe File Location 6-2
Figure 6-5	InstallShield Wizard Screen 6-2
Figure 6-6	Destination Folder Screen 6-2
Figure 6-7	Current Settings Confirmation 6-2
Figure 6-8	Installation Completion Screen 6-2
Figure 6-9	Hardware Update Wizard Screen 1 6-3
Figure 6-10	Hardware Update Wizard Screen 2 6-3
Figure 6-11	Normal Mode Selection 6-3
Figure 6-12	Test Mode Selection 6-3
Figure 6-13	Normal Upgrade Setting 6-4
Figure 6-14	Initial Download Setting 6-4
Figure 6-15	Normal Upgrade Screen 6-4
Figure 6-16	Initial Download Screen 6-4
Figure 6-17	JCM Tool Suite Standard Edition Screen Pull-Down Menu 6-4
Figure 6-18	Browse Screen Button Location 6-4
Figure 6-19	DBV-400 Software Program Selection 6-5
Figure 6-20	Download Progress Screen 1 6-5
Figure 6-21	Download Completed Screen 1 6-5
Figure 6-22	KS-095A Reference Paper 6-5
Figure 6-23	Placing KS-095A Reference Paper 1 (Standard Cash Box) 6-5
Figure 6-24	Placing KS-095A Reference Paper 1 (Rear-Access Cash Box) 6-6
Figure 6-25	Placing KS-095A Reference Paper 2 6-6
Figure 6-26	Placing KS-095A Reference Paper 3 6-6
Figure 6-27	Placing KS-095A Reference Paper 4 6-6
Figure 6-28	Placing KS-095A Reference Paper 5 6-6
Figure 6-29	Placing KS-095A Reference Paper 6 6-7

List of Figures

	Page
Figure 6-30	DIP SW1 Setting 6-8
Figure 6-31	Launching JCM Tool Suite Standard Edition/Sensor Adjustment Selection 6-8
Figure 6-32	Sensor Calibration Screen 1 6-8
Figure 6-33	Sensor Calibration Screen 2 6-8
Figure 6-34	Non-Paper Calibration Screen 6-8
Figure 6-35	Non-Paper Calibration Completion 6-8
Figure 6-36	Placing Reference Paper Message 6-9
Figure 6-37	Reference Paper Calibration 6-9
Figure 6-38	Removing Reference Paper Message 6-9
Figure 6-39	Second Non-Paper Calibration 6-9
Figure 6-40	Serial Number Change Dialogue 6-9
Figure 6-41	Serial Number Setting 6-9
Figure 6-42	Calibration Succeeded Message 6-10
Figure 6-43	Calibration Result 6-10
Figure 6-44	Write EEPROM Succeeded 6-10
Figure 6-45	DS1 Switch Settings 1 6-11
Figure 6-46	JCM Tool Suite Standard Edition Screen/Pull-Down Menu 2 6-11
Figure 6-47	Main Screen 6-11
Figure 6-48	Feed Motor Test Selections 6-12
Figure 6-49	Feed Motor Test Screen 1 6-12
Figure 6-50	Feed Motor Test Screen 2 6-12
Figure 6-51	Stacking Test Selections 6-12
Figure 6-52	Stacking Test Screen 1 6-12
Figure 6-53	Stacking Test Screen 2 6-12
Figure 6-54	Sensor Test Selections 6-13
Figure 6-55	Sensor Test Screen 1 6-13
Figure 6-56	Sensor Test Screen 2 6-13
Figure 6-57	DIP Switch Block Test Selections 6-14
Figure 6-58	DIP Switch Block Test Screen 1 6-14
Figure 6-59	DIP Switch Block Test Screen 2 6-14
Figure 6-60	LED Test Selections 6-14
Figure 6-61	LED Test Screen 1 6-14
Figure 6-62	LED Test Screen 2 6-14
Figure 6-63	Aging Test DIP SW1 Setting 6-15
Figure 6-64	Aging Test DIP SW2 Setting 6-15
Figure 6-65	DIP SW1 #8 OFF 6-15
Figure 6-66	Acceptance Test DIP SW2 Setting 6-16

List of Figures

	Page
Figure 6-67	DIP SW1 #8 OFF For Acceptance Test With Validation 6-16
Figure 6-68	DIP SW1 #8 OFF For Acceptance Test Without Validation 6-16
Figure 6-69	Sensor Test DIP SW1 Setting 6-16
Figure 6-70	Sensor Test DIP SW2 Setting 6-16
Figure 6-71	DIP SW1 #8 OFF 6-16
Figure 6-72	Push Button Location 6-17
Figure 6-73	DIP Switch Test DIP SW2 Setting 6-17
Figure 6-74	DIP SW1 #8 OFF for DS1 Testing 6-17
Figure 6-75	DIP SW1 #8 OFF for DS2 Testing 6-17
Figure 6-76	Other Tests DIP SW2 Setting 6-18
Figure 7-1	Entire DBV-400 Unit Exploded View 7-1
Figure 7-2	DBV-400 Main Unit Exploded View 1 7-3
Figure 7-3	DBV-400 Main Unit Exploded View 2 7-5
Figure 7-4	DBV-400 Validation Guide Cover Assy. Exploded View 7-7
Figure 7-5	DBV-400 Validation Guide Exploded View 7-8
Figure 7-6	DBV-400 Cash Box Exploded View 7-10
Figure 7-7	DBV-400 Bezel Unit Exploded View 7-13
Figure A-1	Additional Maintenance Equipment Requirements A-8

DBV™ Series

DBV-400 Banknote Validator

List of Tables

		Page
Table 1-1	DBV-400 Model Number Specifications	1-2
Table 1-2	DBV-400 Type Number Specifications	1-2
Table 1-3	DBV-400 Software Number Specifications	1-2
Table 1-4	DBV-400 Technical Specifications	1-6
Table 1-5	DBV-400 Environmental Specifications	1-7
Table 1-6	DBV-400 Electrical Specifications	1-7
Table 1-7	DBV-400 Structural Specifications	1-7
Table 2-1	DIP Switch Block 1 Settings	2-1
Table 2-2	DIP Switch Block 2 Settings	2-1
Table 2-3	Bezel LED Color DIP SW2 Settings	2-2
Table 2-4	DBV-400 ID-003 MDB/Photo-Coupler Isolation Connector Pin Assignments	2-3
Table 2-5	DBV-400 ID-003 RS232 Connector Pin Assignments	2-4
Table 2-6	DBV-400 ID-003 TTL Connector Pin Assignments	2-5
Table 2-7	DBV-400 ID-002 Pulse Connector Pin Assignments	2-6
Table 2-8	DBV-400 ID-044 Pulse Connector Pin Assignments	2-7
Table 2-9	DBV-400 ID-044 Serial Connector Pin Assignments	2-8
Table 2-10	DBV-400 USB Interface Connector Pin Assignments	2-9
Table 2-11	DBV-400 USB Maintenance Interface Connector Pin Assignments	2-9
Table 2-12	DBV-400 Sensor Type Cleaning Methods	2-12
Table 6-1	Performance Test Items Using a PC and Test Menu Selections	6-11
Table 6-2	Sensor Test Items	6-13
Table 6-3	Performance Test Items and DIP Switch 1 Settings	6-15
Table 6-4	Aging Test Interval Timing Settings	6-15
Table 6-5	Sensor Test Procedure and Confirmation	6-16
Table 6-6	DIP Switch 1 Test Confirmation	6-17
Table 6-7	DIP Switch 2 Test Confirmation	6-17
Table 6-8	Performance Confirmation	6-18
Table 7-1	Entire DBV-400 Unit Parts List	7-2
Table 7-2	DBV-400 Main Unit Parts List 1	7-4
Table 7-3	DBV-400 Main Unit Parts List 2	7-6
Table 7-4	DBV-400 Validation Guide Cover Assy. Parts List	7-7
Table 7-5	DBV-400 Validation Guide Parts List	7-9
Table 7-6	DBV-400 Cash Box Parts List	7-11
Table 7-7	DBV-400 Bezel Unit Parts List	7-13
Table A-1	General Fault Conditions	A-1
Table A-2	Adjustment Fault Conditions	A-2

List of Tables

	Page
Table A-3 Communication Fault Conditions	A-3
Table A-4 LED Flash Error Codes	A-3
Table A-5 LED Flash Reject Codes	A-6
Table A-6 Additional Maintenance Equipment Parts List	A-8

DBV™ Series

DBV-400 Banknote Validator



Section 1

1 GENERAL INFORMATION

This section provides a general overview of the DBV™ Series DBV-400 Banknote Validator Unit, pictured in Figure 1-1. This section is designed to help the user navigate through this guide with ease. It includes the following information:

- DBV-400 Unit (SU and SD Models)
- Product Descriptions
- Precautions
- Primary Features
- Component Names
- Specifications
- Unit Dimensions
- Technical Contact Information

In order to make operating this device and navigating within this manual easier, the following illustrations are used:

- **Safety Instructions** need to be observed in order to protect the operators and the equipment; these are identified with **Bold** text and the following pictographs: 
- **Special Notes** affect the use of the Banknote Validator; these are identified with *italic* text and the following pictograph: 
- **Steps** require the operator to perform specific actions; these are identified with sequential numbers (1, 2, 3, etc.).

DBV-400 Unit (SU and SD Models)



Figure 1-1 DBV-400 Unit

Product Descriptions

Model Descriptions

Table 1-1 lists the product model number descriptions.

Table 1-1 DBV-400 Model Number Specifications

N ^o	Model: <u>DBV-4</u> <u>***</u> - <u>(*)</u> <u>**</u>
	N ^o (1) (2)(3) (4) (5)
(1)	Model Name
(2)	Validator Sensor 0 = Standard 1-9 = Reserved
(3)	Transport Unit 0 = Standard 1-9 = Reserved
(4)	Optional Unit (Banknote Insertion Section) None = Standard A-Z = Reserved
(5)	Stacker Type SU/SD = Standard SU = Optional Rear-Access Cash Box* SH = Reserved UH = Reserved

*. The optional Rear-Access Cash Box supports SU version only.

Type Descriptions

Table 1-2 lists the product type number descriptions.

Table 1-2 DBV-400 Type Number Specifications

N ^o	Type: <u>***</u> - <u>**</u> - <u>***</u>
	N ^o (1)(2)(3)(4)(5)(6)(7)(8)
(1)	Cash Box Capacity* S = 300 notes (New Banknote) M = 500 notes (New Banknote) L = 1000 notes (New Banknote)
(2)	Cash Box Type 0 = Standard 1 = Optional Rear-Access Cash Box 2 - 9 = Reserved
(3)	Cash Box Door 0 = Standard 1 - 9 = Reserved
(4)	Bezel (Option) 0 = JCM Standard Bezel (Standard) 1 = Snack Mask 2 = TOB 3 = Euro Bezel 4 = Compatible Type Bezel 5 = Snack Mask (Green) 6 - 9 = Reserved A - Z = Reserved
(5)	Centering Guide Chip Type 0 = 66mm 1 = Reserved 2 = 72mm 3 - 9 = Reserved
(6)	Optional Coating 0 = None (Standard) 1 - 9 = Reserved
(7)	Optional Board 0 = None (Standard) 1 - 9 = Reserved
(8)	Interface 0 = None (Standard) 1 = Standard Harness 2 = USB Interface Harness 3 - 9 = Reserved

*. The number of stacked Notes depends on the Banknote's condition.

Software Descriptions

Table 1-3 lists the product software number descriptions.

Table 1-3 DBV-400 Software Number Specifications

N ^o	Software: <u>DBV-400</u> - <u>****</u> - <u>***</u> - <u>V</u> <u>*</u> <u>**</u> - <u>**</u>
	N ^o (A) (B) (C) (D)
(A)	Software Model Name
(B)	Denomination (Country Code)*
(C)	Interface Protocol Name
(D)	Software Version

*. The Country Code is indicated following the ISO 3166 Standard.

Precautions

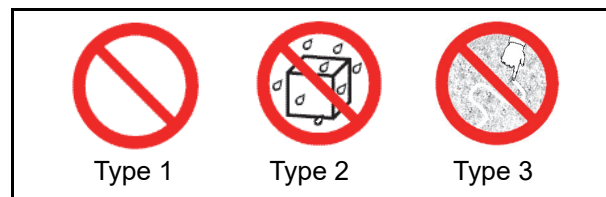

Figure 1-2 Precautionary Symbols

Symbols in Figure 1-2 are defined as follows:

- (Type 1) Do not insert a torn, folded, or wet Banknote; it may cause a jam inside the unit.
- (Type 2) Do not expose the unit to water. The unit contains several precision electronic devices that can be damaged if water or any liquid is sprayed or spilled into the unit.
- (Type 3) Do not install the unit in a dusty environment. Dust may affect/degrade the sensor's performance.

User Cautions

Careful measures were taken in the design of this product to ensure its quality; however, the following cautions pertain to all users and should be followed for safe operation.

Installation Cautions

The Installation Cautions are defined as follows:

- The Unit is not designed for outdoor installation. Be sure that the Host Machine contains enough protection to avoid wet or dusty conditions when installing it in either an indoor or open-air space.
- Ensure that the Host Machine is designed for daily operational access for maintenance and/or clearing a Banknote jam.
- Be careful not to use excessive outside pressure on the Mounting Plate when removing the Cash Box from the Unit.
- Avoid exposing the Unit to direct Sunlight and/or Incandescent Lamp illumination having a Gradient Angle of 15 Degrees or more, and an illumination index of 3000 Lux or less. Ensure that the Host Machine is also designed to avoid exposing the Banknote Insertion Slot to direct Sunlight or Incandescent light.

5. Do not allow the Unit to endure or operate at a high temperature, in high humidity, and/or in a dusty environment (refer to “Environmental Specifications” on page 1-7 of this Section).
6. Do not install the unit in an area where excessive vibration or shock is present.

Mounting, Dismounting & Transportation

Methods for mounting, dismounting and transporting the Unit:

1. Be sure to turn the Power Supply to the Unit OFF before mounting or removing the Unit from its permanent location. Plugging or unplugging Connector Plugs from their receptacles while the Power is ON may cause damage to the Unit.
2. When reassembling a disassembled Unit, ensure that each component is properly replaced in its correct original location.
3. Be sure to carry the Unit by both hands when transporting it. Holding the Unit by one hand may cause personal injury if the Unit accidentally becomes disassembled and drops away.
4. Be careful not to use excessive outside pressure on the Unit, or subject it to excessive vibration during transportation.

Placing Foreign Objects into the Unit

Observe the following precautions when placing foreign objects into the Unit:

1. Do not insert anything except Banknotes into the Insertion Slot. Inserting Receipts, Stapled Tickets, Rubber Bands, or Credit Cards into the Unit may damage the Banknote Transport Path.
2. Do not inject liquids into the Banknote Insertion Slot. Injecting water, oil or cleaning agents may damage the Sensors or plastic parts within the Banknote Transport Path.

Preventive Maintenance

The preventive maintenance requirements are defined as follows:

1. Be sure to turn the Power OFF on the Unit BEFORE beginning a maintenance procedure. The equipment can produce abnormal operating signals while in Maintenance Mode that may cause personal injury.
2. When closing the Validation Guide of the Unit, make sure that it clicks firmly into place.



Caution: Be careful to avoid personal injury to your fingers when closing the Validation Guide Section.

3. Do not disassemble the Unit incorrectly or redesign it in any way. Unauthorized use by inadequately trained personnel, or use outside the original manufacturer’s intent for operation voids the warranty.
4. Perform routine cleaning and maintenance once a month to keep the Unit’s performance optimal.
5. Use a soft, lint-free Micro-fiber cloth, cotton swab and a vacuum cleaner to clean dust and debris from the Banknote Path.



WARNING: To minimize risk of damage to internal printed circuit boards, never allow excess fluid (e.g., from a wet cleaning cloth) to drip or leak into the device. Internal printed circuit boards may be damaged. Do not use any alcohol, citrus based cleaners, solvents or scouring agents that can damage the plastic surfaces of the device.



6. If the Unit is exposed to water or other liquids, use a clean, dry Micro-fiber cloth to wipe off and absorb excess liquids immediately. Any remaining liquids may affect and degrade the Sensors and Validation performance.



Caution: Make Interface Harness connections to the Host Machine shorter than 9.84 Feet (3 Meters) in length. Cut off all unused portions of the Interface Harness wiring to avoid static electrical effects or short circuit possibilities that could cause damage to the Unit.



WARNING: This Unit is designed for use with a Current limiting Power Source! Design the Host Cabinet space to meet all local related safety standards.

Banknote Fitness Requirements

The following Banknote types may not validate correctly, or worse, can cause a Banknote jam and/or damage to the Unit’s Transport Path. Banknotes exhibiting the following conditions illustrated in Figure 1-3 should be avoided:

- torn
- excessive folds or wrinkles
- dirty
- wet
- adhering foreign objects and/or oil

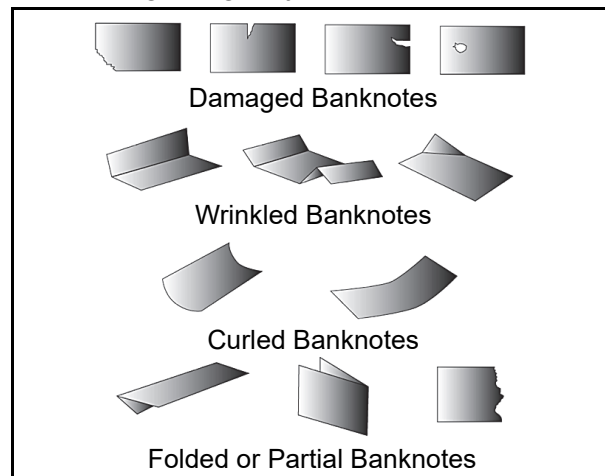

Figure 1-3 Unacceptable Banknotes

Primary Features

The DBV-400 Banknote Validator Unit supports the following primary features:

- **High-Speed Processing** – Validation processing speed by precision high performance Validation Sensors is less than 2 seconds, with a Banknote-to-Banknote processing speed less than 1.7 seconds.
- **High Banknote Acceptance Rates** – 98% or higher using 6 wavelengths of optical sensors. Accepts Banknote widths up to 72mm.
- **Sleep Mode** option provides minimal power consumption in idle status.
- **High Impact Cassettes** - available in 300/500/1000 Banknote capacities.
- **Field service-friendly design** - USB Service Port and DIP Switches are on the Unit's rear panel.
- **Modified design** guards against exposure to liquids and dust.

Component Names

Figure 1-4 illustrates the DBV-400 component names and locations.

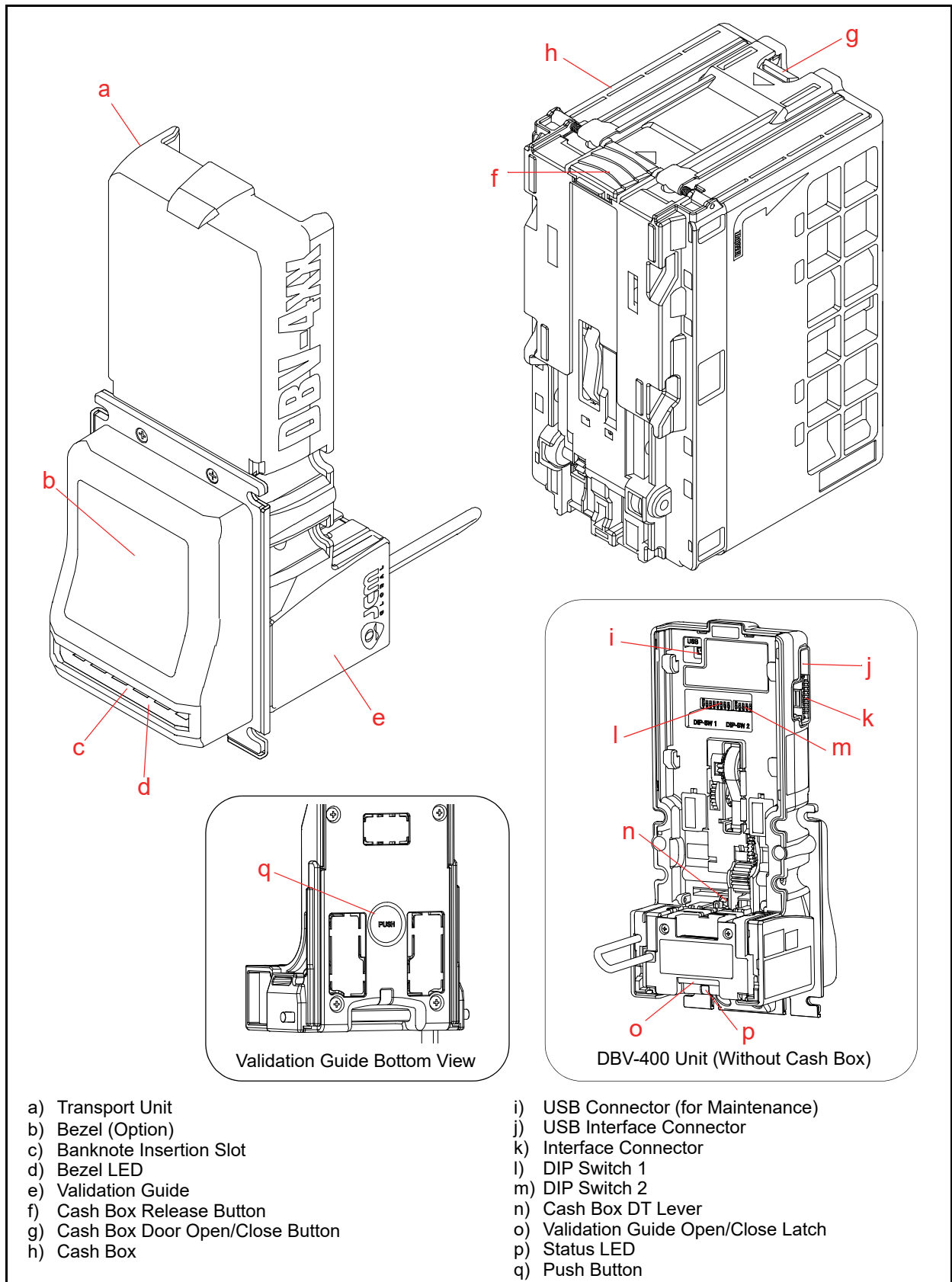

- a) Transport Unit
- b) Bezel (Option)
- c) Banknote Insertion Slot
- d) Bezel LED
- e) Validation Guide
- f) Cash Box Release Button
- g) Cash Box Door Open/Close Button
- h) Cash Box
- i) USB Connector (for Maintenance)
- j) USB Interface Connector
- k) Interface Connector
- l) DIP Switch 1
- m) DIP Switch 2
- n) Cash Box DT Lever
- o) Validation Guide Open/Close Latch
- p) Status LED
- q) Push Button

Figure 1-4 DBV-400 Component Names

Specifications

Technical Specifications

Table 1-4 DBV-400 Technical Specifications

Acceptance Rate* :	98% or greater Note: The following banknote types are excluded: <ul style="list-style-type: none"> • Banknotes with unclear graphics • Double (dual) Notes • Worn, dirty, wet, stained, torn or excessively wrinkled Banknotes • Banknotes having folded corners or edges • Banknotes having the wrong cut dimensions or printing displacement • Returned Banknotes because of incorrect or failed insertion.
Banknote Types Accepted:	<ul style="list-style-type: none"> • Long side: 110 - 160mm (4.33 - 6.29 in.) • Short side: 60 - 72mm (2.36 - 2.83 in.)
Insertion Direction:	Four-Way †
Processing Speed‡:	Approximately 2 seconds (from Banknote insertion to next Banknote insertion)
Validation Method:	Optical Sensor (Transmissive/Reflection)
Diagnostic Indicators:	Bezel LED: Full-Color + Light Amount DA Control Status LED: Red, Green, Blue, Yellow, Magenta, Cyan, White
Escrow:	1 Note
Anti-stringing Mechanism:	Optical Detection and Internal Cash Box Lever
Cash Box Capacity** :	Approximately 300 notes (new Banknotes) Approximately 500 notes (new Banknotes) Approximately 1000 notes (new Banknotes)
Cash Box Access:	Rear Access
Sleep Mode††:	Mode A: Host Wakeup Mode Mode B: Entrance Sensor Wakeup Mode
Interface‡‡:	Photo-Coupler Isolation TTL RS232 Pulse Interface USB (USB Specification Rev. 2.0 Compliance) (Full Speed/12Mbps)

*. Refer to the specific Country's "Software Information Sheet" for each Country's particular Banknote acceptance rate.

†. Refer to the specific Country's "Software Information Sheet" for each Country's particular Banknote insertion direction.

‡. Excluding Host Communication time lag (Power Supply: +12V DC, Temperature: 25° C ±5° C, Humidity: 30%-60%).

** .The number of Notes stacked depends on the Banknote's condition.

††.Both Mode A and Mode B can be available at the same time.

‡‡.The Interface Harness connecting to the Host should be less than 3m (9.84 ft).

Environmental Specifications

Table 1-5 DBV-400 Environmental Specifications

Operating Temperature:	-15°C to +60°C (5°F to 140°F)*
Storage Temperature:	-20°C to +60°C (-4°F to 140°F)*
Relative Operating Humidity:	15% to 90% RH (non-condensed)
Relative Storage Humidity:	30% to 65% RH (non-condensed)
Visible Light Sensitivity:	Avoid contact with direct sunlight (Interior lighting must be incandescent with a Radiant Angle of 15 Degrees or more having an Illumination index of 3000 Lux or less)
Installation:	Indoors Only

*. Depends on hydrothermal conditions.

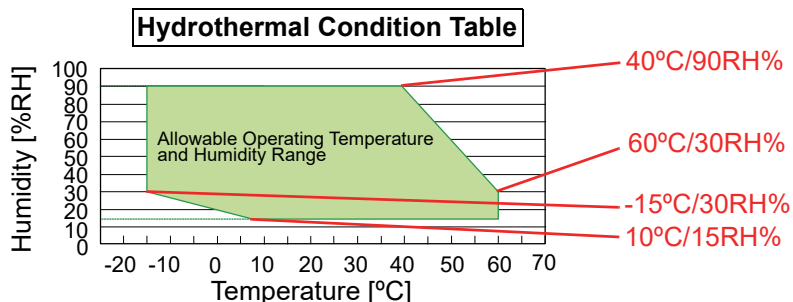

Electrical Specifications

Table 1-6 DBV-400 Electrical Specifications

Supply Voltage* :	12V DC (-5%) - 24V DC (+5%) †
Current Consumption:	<p>Standard Operation ‡</p> <ul style="list-style-type: none"> Inrush = 12V DC = 2.5A, 24V DC = 2.0A Standby = 12V DC = 0.12A, 24V DC = 0.07A Operation = 12V DC = 1.4A, 24V DC = 0.7A Peak = 12V DC = 2.2A, 24V DC = 1.6A <p>Sleep Mode (Standby)**</p> <ul style="list-style-type: none"> Mode A = 35µA †† Mode B = 95µA ††

*. Use a Current Source Limiting Power Supply.

†. The DBV-400 Unit is designed to be connected to a Power Supply having any voltage between 12V DC and 24V DC.

‡. The Standard Operation indicates the DBV-400 Unit current range.

** The two Sleep Mode options (Mode A [Host Wakeup Mode]/Mode B [Entrance Sensor Wakeup Mode]) can be used at the same time.

††. A representative value derived from actual and designed values.

Structural Specifications

Table 1-7 DBV-400 Structural Specifications

Weight:	<p>DBV-400 Unit (with the Bezel): Approximately 0.89kg (1.96lbs.)</p> <p>DBV-400 with Small Cash Box (300 notes): Approximately 1.34kg (2.95lbs.)</p> <p>DBV-400 with Medium Cash Box (500 notes): Approximately 1.42kg (3.31lbs.)</p> <p>DBV-400 with Large Cash Box (1000 notes): Approximately 1.62kg (3.57lbs.)</p>
Mounting:	Horizontal
Outside Dimensions:	See "Entire Unit Outside Dimensions" on page 1-8 of this Manual

Unit Dimensions

Entire Unit Outside Dimensions

Figure 1-5 illustrates the DBV-400 Unit with JCM Standard Bezel outside dimensions.

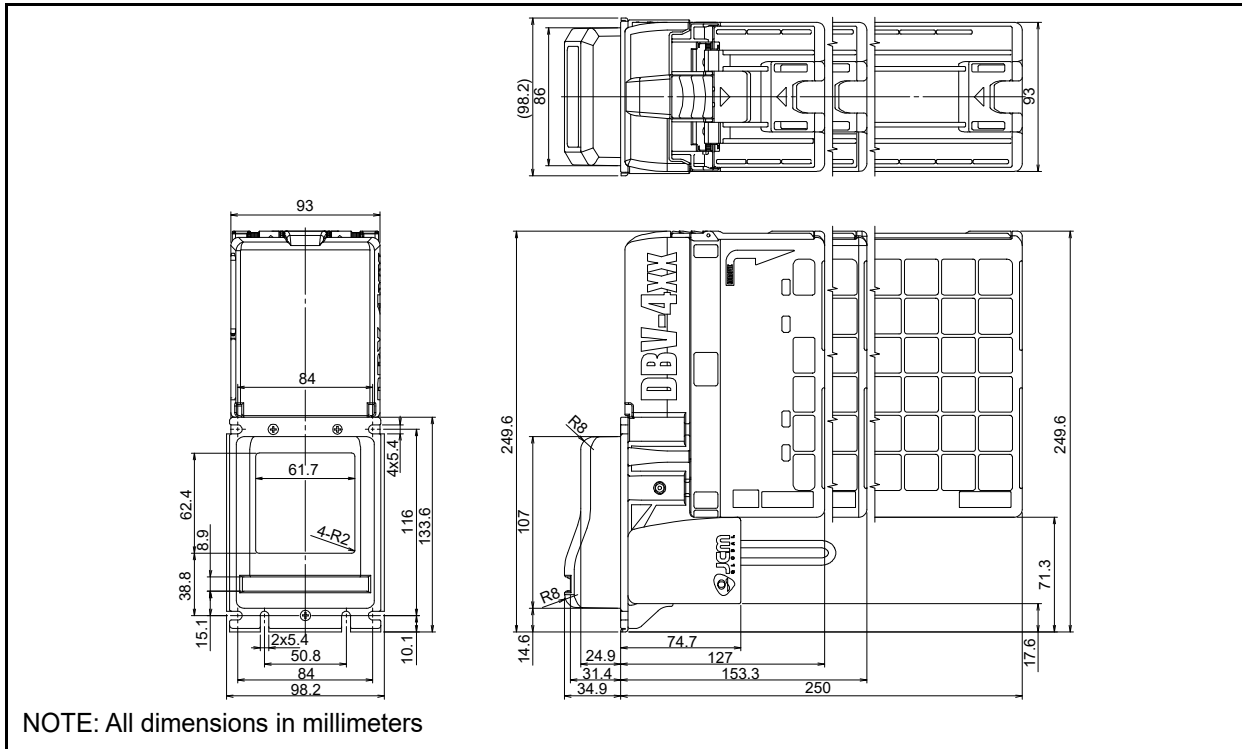

Figure 1-5 DBV-400 Unit With JCM Standard Bezel Outside Dimensions

Figure 1-6 illustrates the DBV-400 Unit with Snack Mask Bezel outside dimensions.

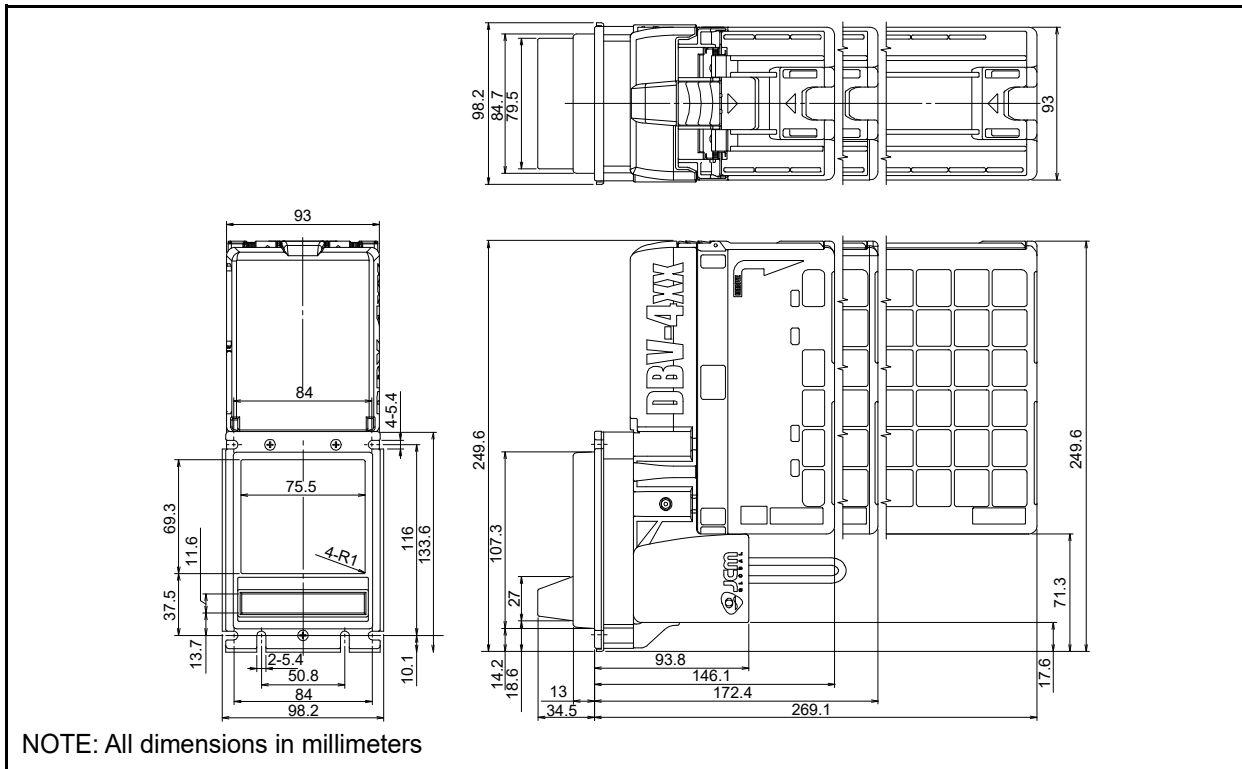

Figure 1-6 DBV-400 Unit With Snack Mask Bezel Outside Dimensions

Entire Unit Outside Dimensions (Continued)

Figure 1-7 illustrates the DBV-400 Unit with TOB Type Bezel outside dimensions.

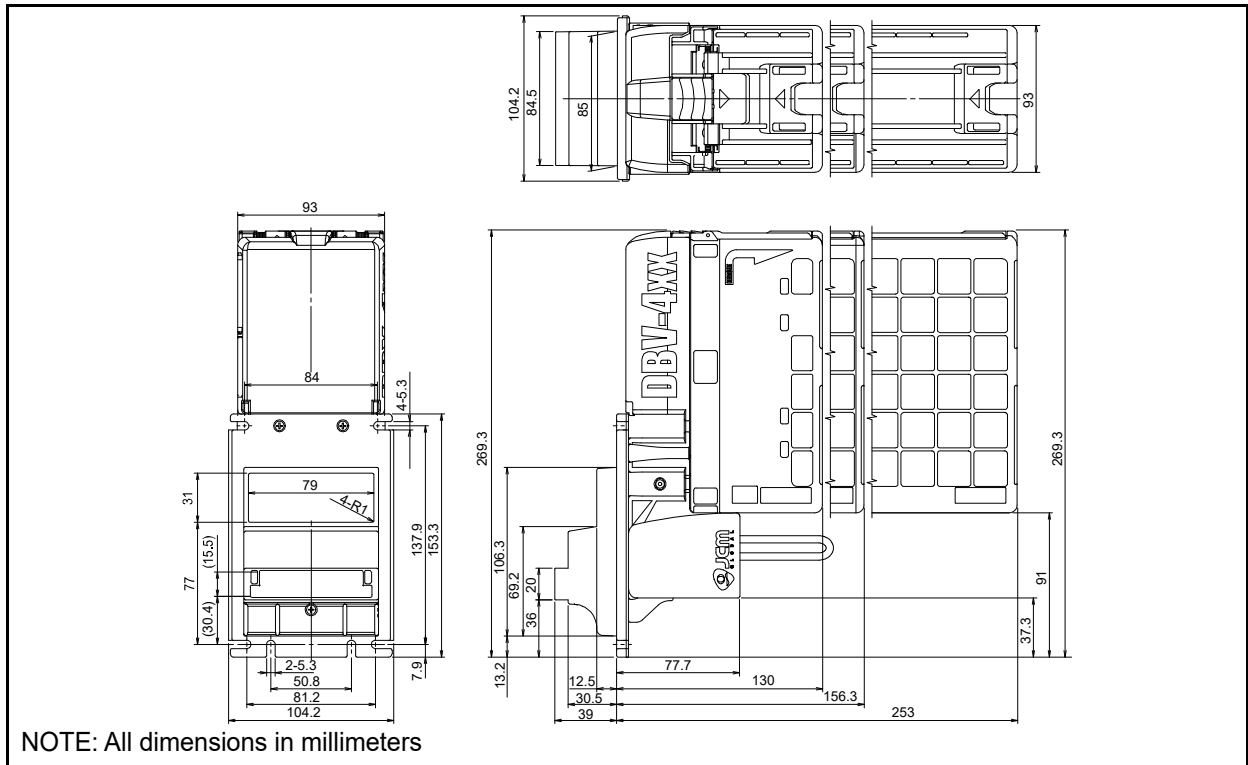

Figure 1-7 DBV-400 Unit With TOB Type Bezel Outside Dimensions

Figure 1-8 illustrates the DBV-400 Unit with Euro Type Bezel outside dimensions.

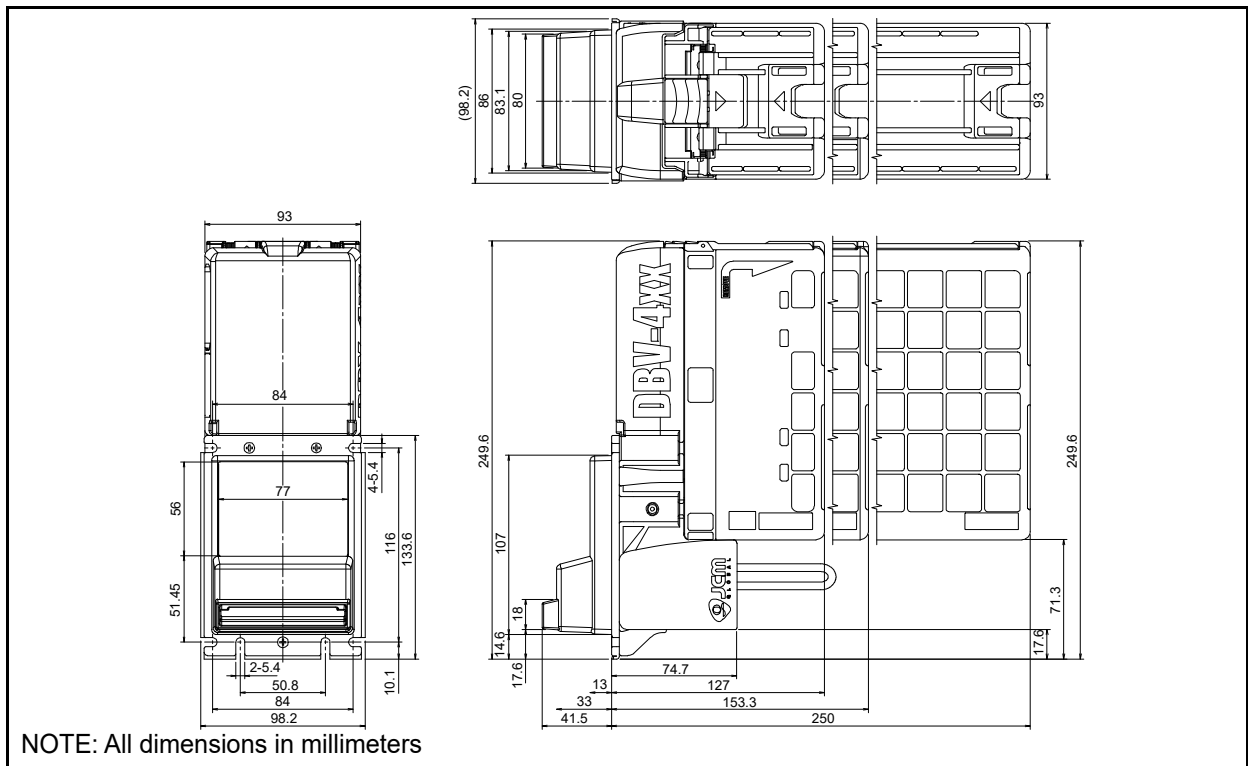

Figure 1-8 DBV-400 Unit With Euro Type Bezel Outside Dimensions

Entire Unit Outside Dimensions (Continued)

Figure 1-9 illustrates the DBV-400 Unit with Compatible Type Bezel outside dimensions.

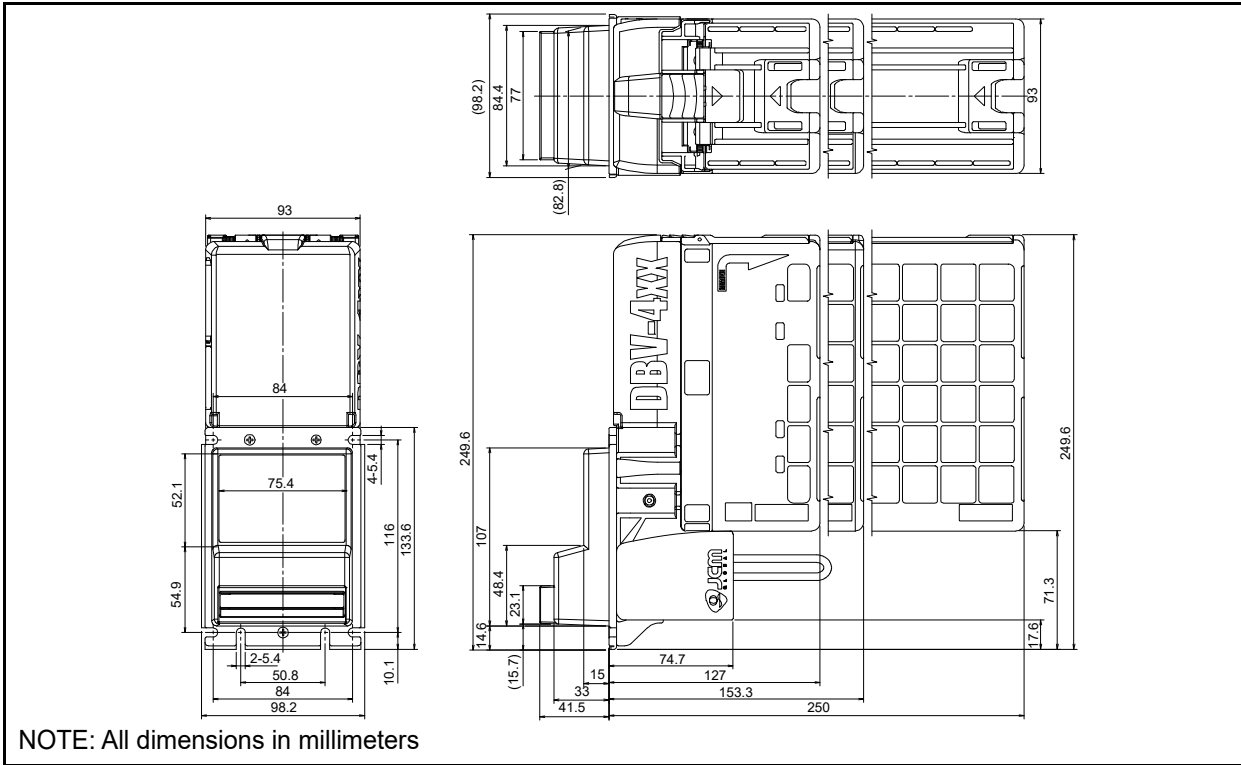

Figure 1-9 DBV-400 Unit With Compatible Type Bezel Outside Dimensions

Technical Contact Information

Americas

JCM American

Phone: +1-702-651-0000

Fax: +1-702-644-5512

925 Pilot Road,
Las Vegas, NV 89119

E-mail: support@jcmglobal.com

Europe, Middle East, Africa & Russia

JCM Europe GmbH

Phone: +49-211-530-645-60

Fax: +49-211-530-645-85

Mündelheimer Weg 60 D-40472
Düsseldorf Germany

E-mail: support@jcmglobal.eu

UK & Ireland

JCM Europe (UK Office)

Phone: +44 (0) 190-837-7331

Fax: +44 (0) 190-837-7834

Luminous House, 300 South Row,
Milton Keynes MK9 2FR, United Kingdom

E-mail: support@jcmglobal.eu

Asia and Oceania

JCM American (Australia Office)

Phone: +61-2-9648-0811

Fax: +61-2-9647-1438

Unit 21, 8 Avenue of the Americas Newington,
NSW 2127 Australia

E-mail: Sales-AsiaPac@jcmglobal.com

JAPAN CASH MACHINE CO., LTD. (HQ)

Phone: +81-6-6703-8400

Fax: +81-6-6707-0348

2-3-15, Nishiwaki, Hirano-ku,
Osaka 547-0035 JAPAN

E-mail: Shohin@jcm-hq.co.jp

The JCM Website for all locations is:
<http://www.jcmglobal.com>

THIS PAGE INTENTIONALLY LEFT BLANK

DBV™ Series

DBV-400 Banknote Validator

Section 2

2 INSTALLATION

This section provides installation and operating instructions for the DBV™ Series DBV-400 Banknote Validator Unit. The following information is discussed within this section:

- Installation Procedure
- DIP Switch Configurations
- Connector Pin Assignments
- Preventive Maintenance
- Standard Interface Circuit Schematics
- Operational Flowchart

Installation Procedure

The DBV-400 Frame Unit provides installation grooves (notches) for each surface.

Entire Unit Installation

Perform the following steps to install the DBV-400 Unit:

1. Place the DBV-400 Unit Frame cut outs (Figure 2-1 a_1 through a_4 and b_1 & b_2) onto the threaded studs on the chassis.
2. Secure the rear side of the DBV-400 Frame to the chassis with six (6) nuts.

 **NOTE:** Refer to "Unit Dimensions" on page 1-8 for each Bezel's dimensions.

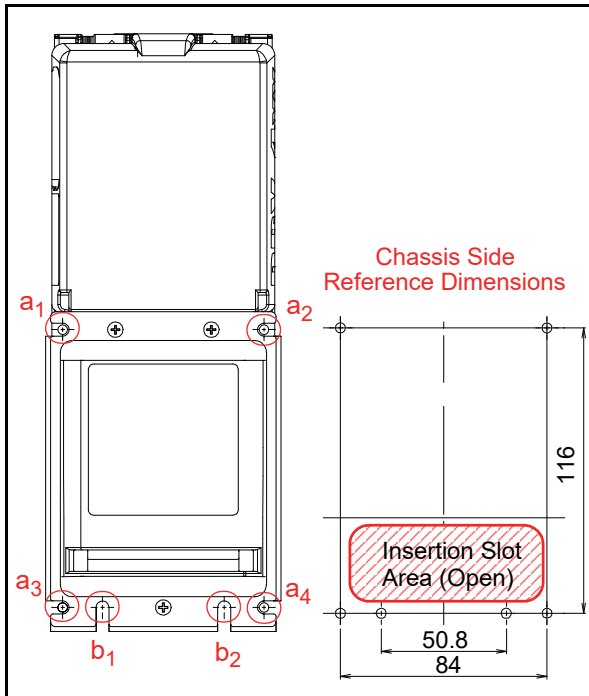



Figure 2-1 Threaded Studs Location

DIP Switch Configurations

This section provides the DIP Switch Block 1 (**DIP SW1**) and Block 2 (**DIP SW2**) Settings for the DBV-400 Unit and its Bezel.

 **NOTE:** Turn the Power Supply to the DBV-400 Unit OFF before configuring settings on DIP Switch Block 1 and Block 2.

DIP Switch Block 1

DIP Switch Block 1 (**DIP SW1**) is used to Accept (enable) or Inhibit (disable) acceptance of each Banknote denomination.

Table 2-1 DIP Switch Block 1 Settings

Switch No.	Switch ON	Switch OFF
1	VEND 1 INHIBIT	VEND 1 ACCEPT
2	VEND 2 INHIBIT	VEND 2 ACCEPT
3	VEND 3 INHIBIT	VEND 3 ACCEPT
4	VEND 4 INHIBIT	VEND 4 ACCEPT
5	VEND 5 INHIBIT	VEND 5 ACCEPT
6	VEND 6 INHIBIT	VEND 6 ACCEPT
7	VEND 7 INHIBIT	VEND 7 ACCEPT
8	TEST MODE	FUNCTION

DIP Switch Block 2

DIP Switch Block 2 (**DIP SW2**) is used to set various functions.

Table 2-2 DIP Switch Block 2 Settings

Switch No.	Switch ON	Switch OFF
1	Refer to the "Software Information Sheet" for details on DIP Switch Block 2 (DIP SW2) settings.	
2		
3		
4		
5		
6		
7		
8		

Bezel LED Default Color Settings

To change the Bezel LED’s default color, proceed as follows:

1. Remove electrical power from the DBV-400 Unit.
2. Set the DBV-400 DIP SW1 #1, #4, #5, #6, #7 and #8 to **ON** (Figure 2-2).

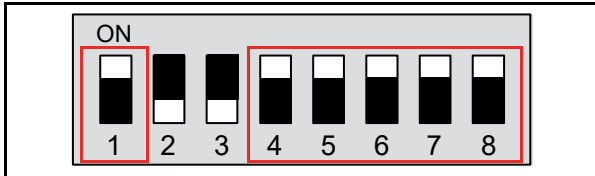

Figure 2-2 Bezel LED Color DIP SW1 Settings

3. Connect the Power Harness and apply electrical power to the DBV-400 Unit.
4. Select the desired Bezel LED color by setting the DIP SW2 as indicated in Table 2-3.

Table 2-3 Bezel LED Color DIP SW2 Settings

Bezel LED Color	DIP Switch 2 Setting							
	1	2	3	4	5	6	7	8
Green	ON							
Cyan		ON						
Blue			ON					
Magenta				ON				
White					ON			
Gradation (fading)						ON		

5. Set the DIP SW1 #8 to **OFF** to configure the default Bezel LED color.

This completes the default Bezel LED default color settings procedure.

Connector Pin Assignments

Table 2-4 through Table 2-11 list the DBV-400 Unit's pin assignments.

MDB/Photo-Coupler Isolation Connector Pin Assignments

Table 2-4 lists the DBV-400 ID-003 MDB/Photo-Coupler Isolation Connector Pin Assignments.

Table 2-4 DBV-400 ID-003 MDB/Photo-Coupler Isolation Connector Pin Assignments

Pin No.	Signal Name	I/O*	Function
1	+12V - +24V	-	Power Supply
2	GND	-	Power Ground (0V DC)
3	+12V - +24V	-	Power Supply
4	GND	-	Power Ground (0V DC)
5	TXD	OUT	Serial Communication Output Signal Line
6	RXD	IN	Serial Communication Input Signal Line
7	COMMON	-	Photo-Coupler Common Signal Line
8	-	-	Reserved
9	-	-	Reserved
10	GND	-	Signal Ground (0V DC)
11	-	-	Reserved
12	-	-	Reserved
13	-	-	Reserved
14	-	-	Reserved
15	-	-	Reserved
16	-	-	Reserved
17	-	-	Reserved
18	VCCSYNC	IN	Wakeup Input Signal Line

*. I/O (input/output) is the terminal as viewed from the Banknote Validator's side.

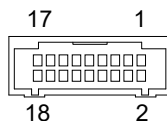

CN1 Connector (DBV-400 Side): 74164-0118 (Molex)

Housing (Cable Side): 50-57-9309 SL™ Crimp Housing, Single Row, Version D, Back Ribs, 9 Circuits (Molex)

015-04-5184 2.54mm SL™ Interim Clip, 18 Circuits, Polarized (Molex)

16-02-0069 SL™ Crimp Terminal, Series70058, Female, with Tin (Sn) Plated Contact, 24-30 AWG

(Maximum Insulation Diameter: Less than φ1.52) (Molex)

Recommended Wire (for Power Supply and Power Ground): Insulation Diameter AWG #24 (Maximum Insulation Diameter: Less than φ1.52)

Recommended Wire (for Signal Ground): AWG #24 - 30 (Maximum Insulation Diameter: Less than φ1.52)

RS232 Connector Pin Assignments

Table 2-5 lists the DBV-400 ID-003 RS232 Connector Pin Assignments.

Table 2-5 DBV-400 ID-003 RS232 Connector Pin Assignments

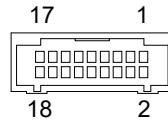

CN1 Connector (DBV-400 Side): 74164-0118 (Molex)

Housing (Cable Side): 50-57-9309 SL™ Crimp Housing, Single Row, Version D, Back Ribs, 9 Circuits (Molex)

015-04-5184 2.54mm SL™ Interim Clip, 18 Circuits, Polarized (Molex)

16-02-0069 SL™ Crimp Terminal, Series70058, Female, with Tin (Sn) Plated Contact, 24-30 AWG (

Maximum Insulation Diameter: Less than $\phi 1.52$) (Molex)

Recommended Wire (for Power Supply and Power Ground): AWG #24 (Maximum Insulation Diameter: Less than $\phi 1.52$)

Recommended Wire (for Signal Ground): AWG #24 - 30 (Maximum Insulation Diameter: Less than $\phi 1.52$)

Pin No.	Signal Name	I/O*	Function
1	+12V - +24V	-	Power Supply
2	GND	-	Power Ground (0V DC)
3	+12V - +24V	-	Power Supply
4	GND	-	Power Ground (0V DC)
5	-	-	Reserved
6	-	-	Reserved
7	-	-	Reserved
8	TXD	OUT	Serial Communication Output Signal Line
9	RXD	IN	Serial Communication Input Signal Line
10	GND	-	Signal Ground (0V DC)
11	-	-	Reserved
12	-	-	Reserved
13	-	-	Reserved
14	-	-	Reserved
15	-	-	Reserved
16	-	-	Reserved
17	-	-	Reserved
18	-	-	Reserved

*. I/O (input/output) is the terminal as viewed from the Banknote Validator's side.

TTL Connector Pin Assignments

Table 2-6 lists the DBV-400 ID-003 TTL Connector Pin Assignments.

Table 2-6 DBV-400 ID-003 TTL Connector Pin Assignments

Pin No.	Signal Name	I/O*	Function
1	+12V - +24V	-	Power Supply
2	GND	-	Power Ground (0V DC)
3	+12V - +24V	-	Power Supply
4	GND	-	Power Ground (0V DC)
5	-	-	Reserved
6	-	-	Reserved
7	-	-	Reserved
8	-	-	Reserved
9	-	-	Reserved
10	GND	-	Signal Ground (0V DC)
11	TXD	OUT	Serial Communication Output Signal Line [†]
12	RXD	IN	Serial Communication Input Signal Line [†]
13	-	-	Reserved
14	-	-	Reserved
15	-	-	Reserved
16	-	-	Reserved
17	-	-	Reserved
18	-	-	Reserved

*. I/O (input/output) is the terminal as viewed from the Banknote Validator's side.

†. The voltage level should be based on the TTL logic levels.

ID-002 Pulse Connector Pin Assignments

Table 2-7 lists the DBV-400 ID-002 Pulse Connector Pin Assignments.

Table 2-7 DBV-400 ID-002 Pulse Connector Pin Assignments

Pin No.	Signal Name	I/O*	Function
1	+12V - +24V	-	Power Supply
2	GND	-	Power Ground (0V DC)
3	+12V - +24V	-	Power Supply
4	GND	-	Power Ground (0V DC)
5	-	-	Reserved
6	-	-	Reserved
7	-	-	Reserved
8	-	-	Reserved
9	-	-	Reserved
10	GND	-	Signal Ground (0V DC)
11	VEND	OUT	VEND †
12	-	-	Reserved
13	-	-	Reserved
14	D/E	IN	D/E †
15	-	-	Reserved
16	BUSY	OUT	BUSY †
17	ABN	OUT	ABN †
18	FULL	OUT	FULL †

*. I/O (input/output) is the terminal as viewed from the Banknote Validator's side.

†. The voltage level should be based on the TTL logic levels.

ID-044 Pulse Connector Pin Assignments

Table 2-8 lists the DBV-400 ID-044 Pulse Connector Pin Assignments.

Table 2-8 DBV-400 ID-044 Pulse Connector Pin Assignments

Pin No.	Signal Name	I/O*	Function
1	+12V - +24V	-	Power Supply
2	GND	-	Power Ground (0V DC)
3	+12V - +24V	-	Power Supply
4	GND	-	Power Ground (0V DC)
5	-	-	Reserved
6	-	-	Reserved
7	-	-	Reserved
8	-	-	Reserved
9	-	-	Reserved
10	GND	-	Signal Ground (0V DC)
11	VEND	OUT	VEND [†]
12	-	-	Reserved
13	-	-	Reserved
14	D/E	IN	D/E [†]
15	-	-	Reserved
16	-	-	Reserved
17	-	-	Reserved
18	-	-	Reserved

*. I/O (input/output) is the terminal as viewed from the Banknote Validator's side.

†. The voltage level should be based on the TTL logic levels.

ID-044 Serial Connector Pin Assignments

Table 2-9 lists the DBV-400 ID-044 Serial Connector Pin Assignments.

Table 2-9 DBV-400 ID-044 Serial Connector Pin Assignments

Pin No.	Signal Name	I/O*	Function
1	+12V - +24V	-	Power Supply
2	GND	-	Power Ground (0V DC)
3	+12V - +24V	-	Power Supply
4	GND	-	Power Ground (0V DC)
5	-	-	Reserved
6	-	-	Reserved
7	-	-	Reserved
8	-	-	Reserved
9	-	-	Reserved
10	GND	-	Signal Ground (0V DC)
11	TXD	OUT	Serial Communication Output Signal Line
12	CTS	IN	CTS
13	-	-	Reserved
14	D/E	IN	D/E †
15	SOFT-R	IN	SOFT-R †
16	BUSY	OUT	BUSY †
17	ABN	OUT	ABN †
18	RTS	OUT	RTS †

*. I/O (input/output) is the terminal as viewed from the Banknote Validator's side.

†. The voltage level should be based on the TTL logic levels.

USB Interface Connector Pin Assignments

Table 2-10 lists the DBV-400 USB Interface Connector Pin Assignments.

Table 2-10 DBV-400 USB Interface Connector Pin Assignments

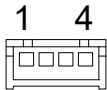
 CN2 Connector (DBV-400 Side): S4B-XH-A (JST) Housing (Cable Side): XHP-4B (JST) Contact (Cable Side): SXH-001T-PO.6 (JST)			
Pin No.	Signal Name	I/O*	Function
1	Vbus	-	Vbus
2	D-	IN/OUT	D-
3	D+	IN/OUT	D+
4	GND	-	GND

*. I/O (input/output) is the terminal as viewed from the Banknote Validator's side.

USB Maintenance Interface Connector Pin Assignment

Table 2-11 lists the DBV-400 USB Maintenance Interface Connector Pin Assignments.

Table 2-11 DBV-400 USB Maintenance Interface Connector Pin Assignments

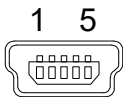
 CN5 Connector (DBV-400 Side): USB Specification Rev. 2.0 Compliance Mini-B Type Housing (Cable Side): USB Specification Rev. 2.0 Compliance Mini-B Type			
Pin No.	Signal Name	I/O*	Function
1	Vbus	-	Vbus
2	D-	IN/OUT	D-
3	D+	IN/OUT	D+
4	ID	-	No Connection
5	GND	-	GND

*. I/O (input/output) is the terminal as viewed from the Banknote Validator's backside.

Preventive Maintenance

Retrieving Banknotes

To retrieve Cash Box deposited Banknotes, perform the following steps:

1. Press the Cash Box Release Button (Figure 2-3 a) in the direction indicated by the blue arrow and slightly pull the Cash Box upward and then out in the direction indicated by the red arrow A.

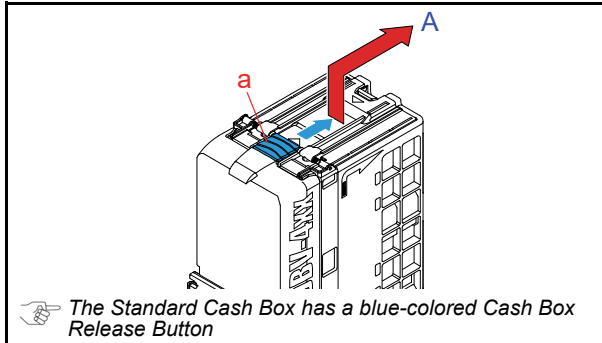

Figure 2-3 Retrieving Banknotes 1 (Standard Cash Box)

In the case of the optional Rear-Access Cash Box, pressing the Cash Box Release Button (Figure 2-4 a) can be skipped. Pull the Rear-Access Cash Box upward (Figure 2-4 ①) to unlock the Box Latch and then out in the direction Figure 2-4 ②.

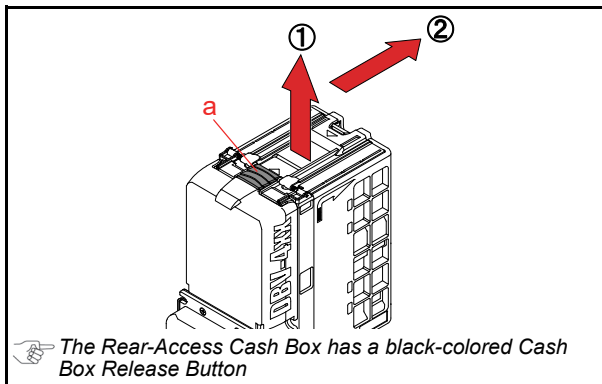

Figure 2-4 Retrieving Banknotes 1 (Rear-Access Cash Box)

2. Press the Cash Box Door Open/Close Button (Figure 2-5 a) to open the Cash Box Door and retrieve the Banknotes.

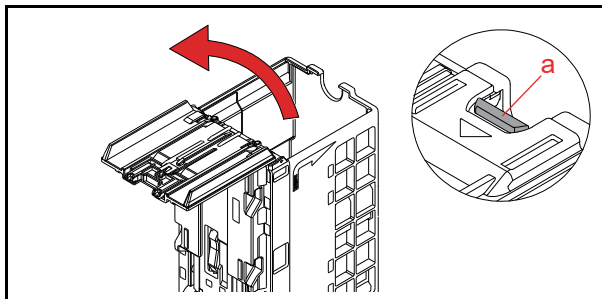

Figure 2-5 Retrieving Banknotes 2

Clearing a Banknote Jam

To retrieve a jammed Banknote located inside the Banknote Validator, proceed as follows:

1. Press the Validation Guide Open/Close Latch (Figure 2-6 a) upward and pull the Validation Guide out of the DBV-400 Unit as indicated by the red arrow A.

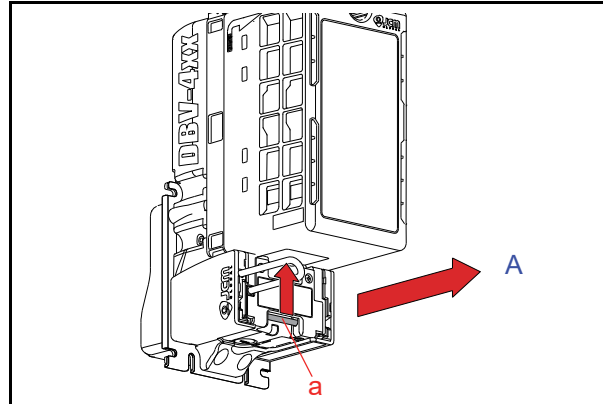

Figure 2-6 Clearing a Banknote Jam 1

2. Remove the jammed Banknote (Figure 2-7).

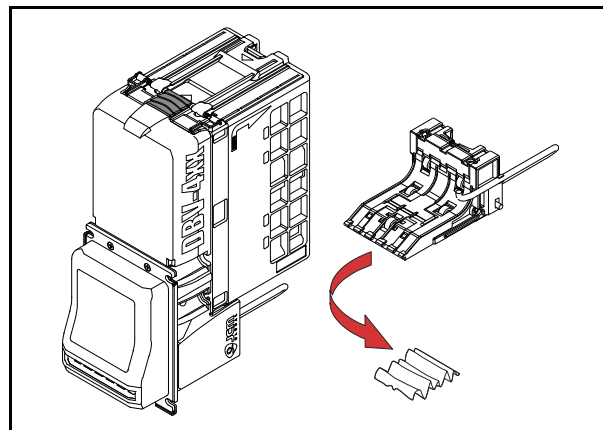

Figure 2-7 Clearing a Banknote Jam 2

3. When a jammed Banknote is not visible, open the Cash Box Door and remove any jammed Banknote (Figure 2-8).

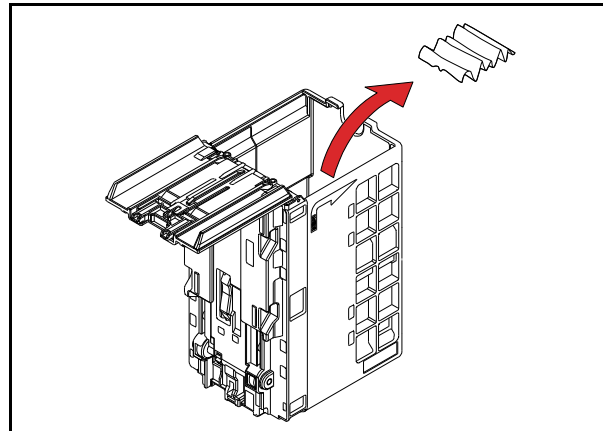

Figure 2-8 Clearing a Banknote Jam 3

Cleaning Procedure

To clean the DBV-400 Validation Section, use a soft, dry (or slightly damp with water) lint-free Micro-fiber Cloth or a vacuum cleaner.

Do not use any alcohol, solvents, citrus based products, or scouring agents that may cause damage to the Validation Section Sensors and/or Rollers.

Sensor and Roller Cleaning Procedure

To clean the DBV-400 Unit's Sensors and Rollers, proceed as follows:

1. Turn the Power Supply to both the DBV-400 Unit and the Host Machine **OFF**.
2. Remove the Cash Box from the DBV-400 Unit (Figure 2-3 or Figure 2-4) and pull the Validation Guide out of the DBV-400 Unit (Figure 2-6).
3. Clean the appropriate path and Lens of each Sensor (See Figure 2-10 for Sensor and Roller locations & Table 2-12 for each Sensor Type cleaning method).



Caution: Do not use alcohol, thinner or citrus based products for cleaning any Banknote Transport Sensors or surfaces. The lenses can become clouded by chemical evaporation residue that may cause acceptance errors.



Caution: Do not place a vacuum cleaner nozzle directly on the surface of the DBV-400 Unit, to avoid scratches to the Sensor Lens.

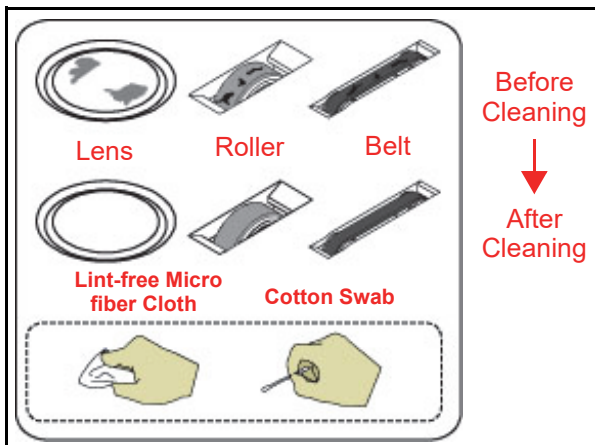

Figure 2-9 General Cleaning Image

Sensor and Roller Locations

Figure 2-10 illustrates the DBV-400 Unit's various sensor and roller cleaning locations. Table 2-12 lists the DBV-400 sensor type cleaning methods.

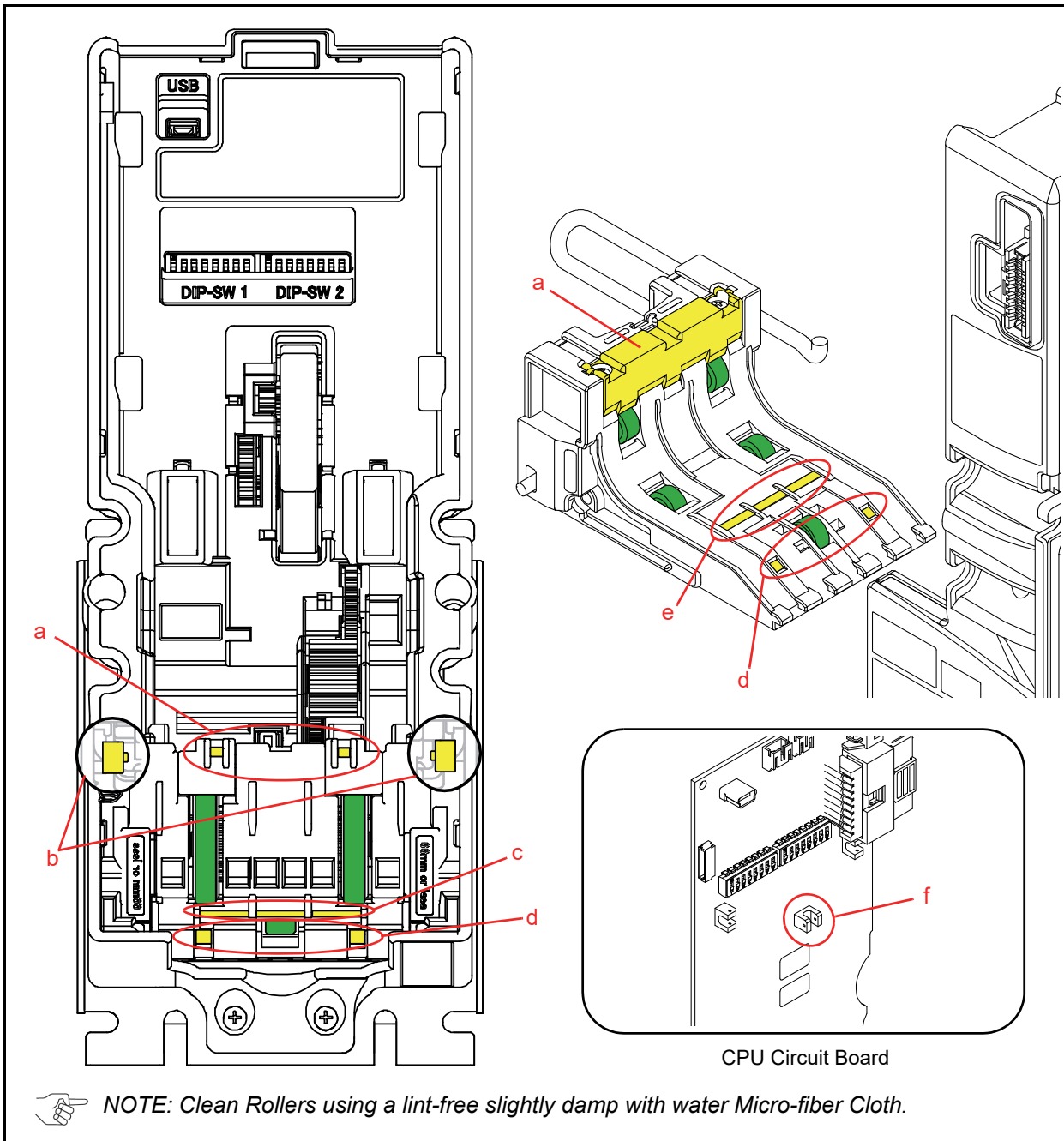

Figure 2-10 DBV-400 Sensor and Roller Cleaning Locations

Table 2-12 DBV-400 Sensor Type Cleaning Methods

Sym.	Sensor/Roller Type	Cleaning Method
a	Exit Sensor	Wipe clean using a soft lint-free Micro-fiber Cloth or vacuum clean using a vacuum cleaner.
b	Side Sensor	
c	Inside Validation Sensor	
d	Entrance Sensor	
e	Outside Validation Sensor	
f	Pusher Home Sensor	

Standard Interface Circuit Schematics

Figure 2-11 illustrates the DBV-400 ID-003 MDB/Photo-Coupler Isolation Interface Schematic Diagram.

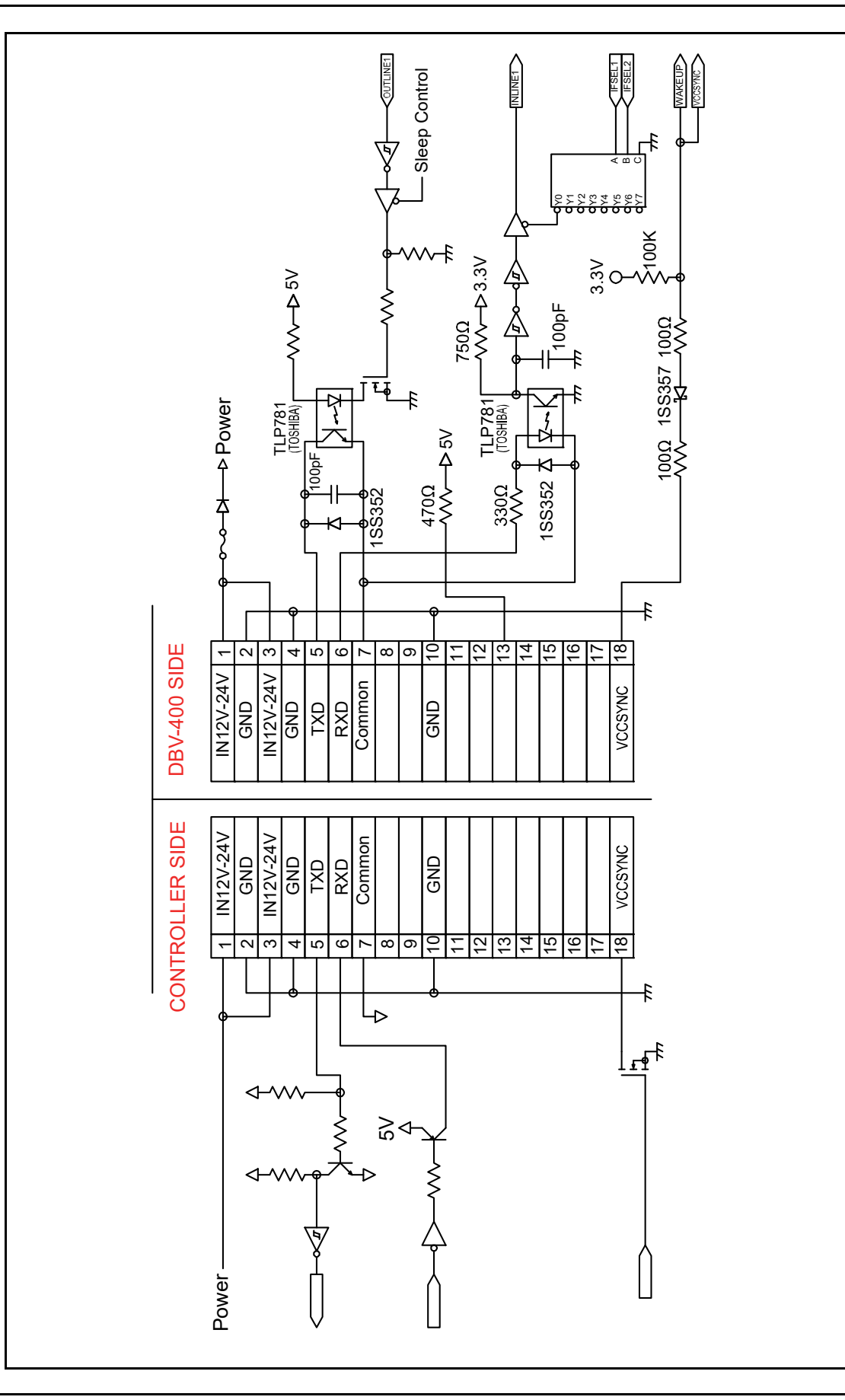

Figure 2-11 DBV-400 ID-003/MDB Photo-Coupler Isolation Interface Schematic Diagram

Standard Interface Circuit Schematics (Continued 2)

Figure 2-13 illustrates the DBV-400 ID-003 TTL Interface Schematic Diagram.

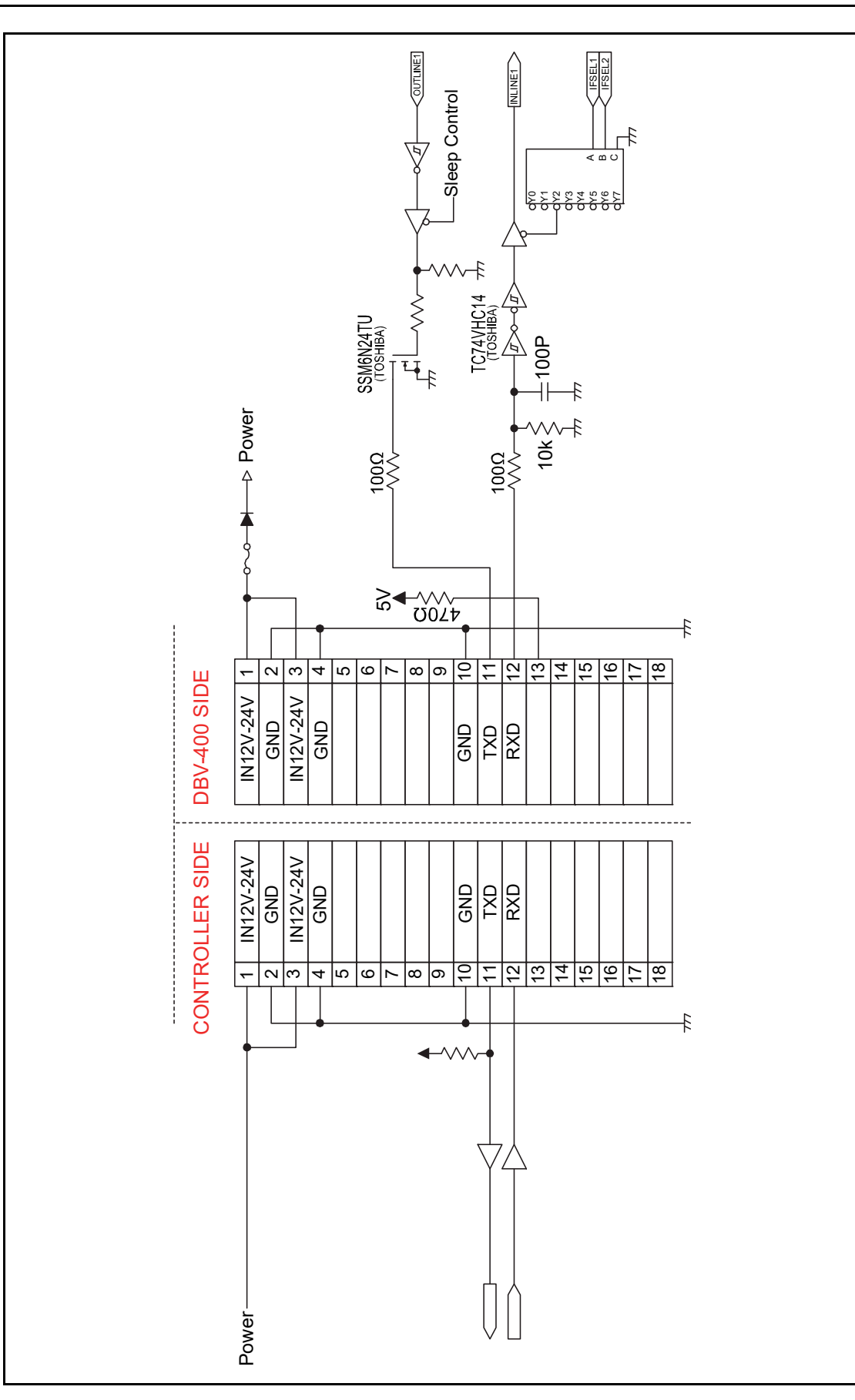

Figure 2-13 DBV-400 ID-003 TTL Interface Schematic Diagram

Standard Interface Circuit Schematics (Continued 3)

Figure 2-14 illustrates the DBV-400 ID-002 Pulse Interface Schematic Diagram.

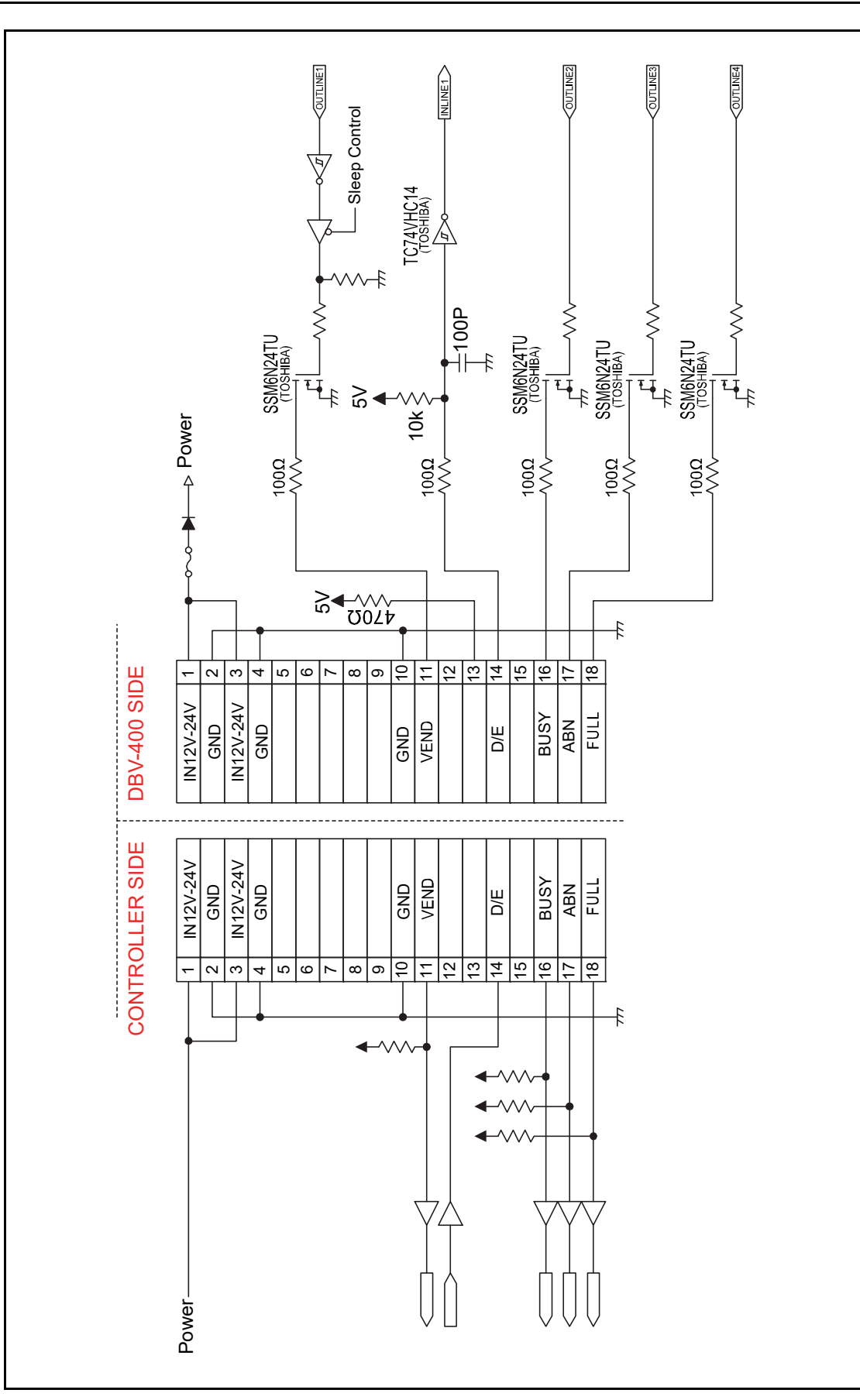

Figure 2-14 DBV-400 ID-002 Pulse Interface Schematic Diagram

Standard Interface Circuit Schematics (Continued 4)

Figure 2-15 illustrates the DBV-400 ID-044 Pulse Interface Schematic Diagram.

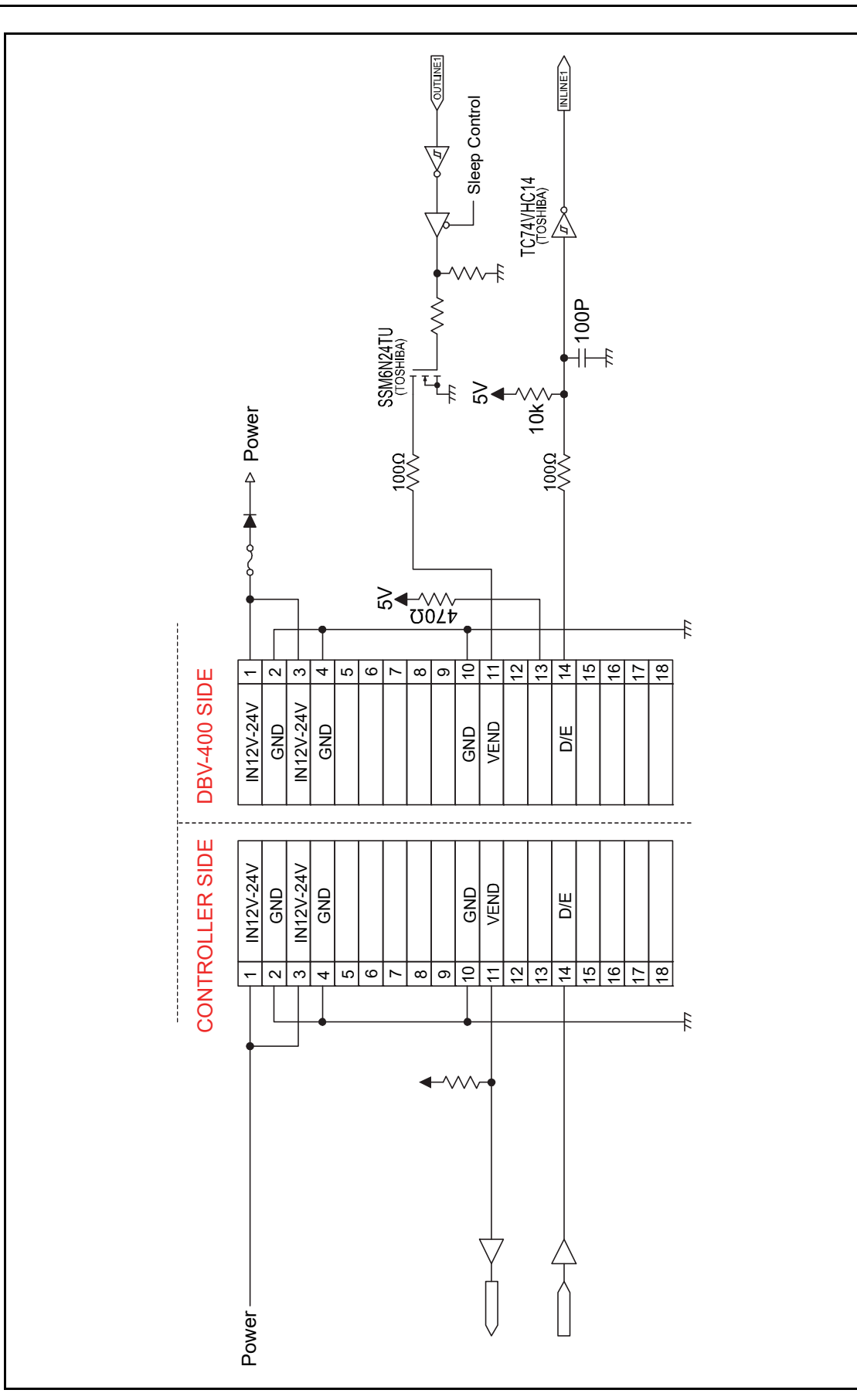

Figure 2-15 DBV-400 ID-044 Pulse Interface Schematic Diagram

Standard Interface Circuit Schematics (Continued 5)

Figure 2-16 illustrates the DBV-400 ID-044 Serial Interface Schematic Diagram.

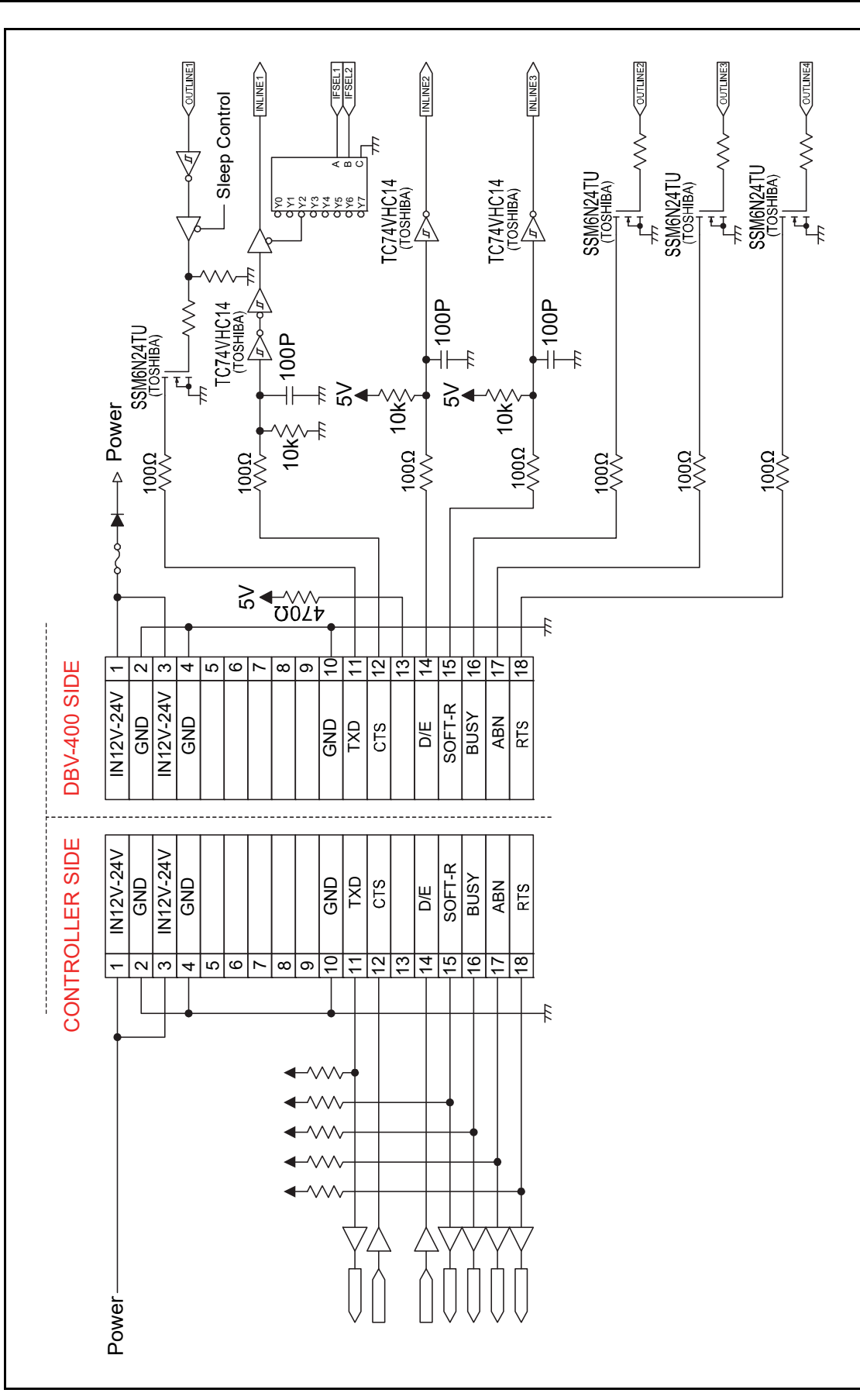

Figure 2-16 DBV-400 ID-044 Serial Interface Schematic Diagram

Standard Interface Circuit Schematics (Continued 6)

Figure 2-17 illustrates the DBV-400 USB Interface Schematic Diagram.

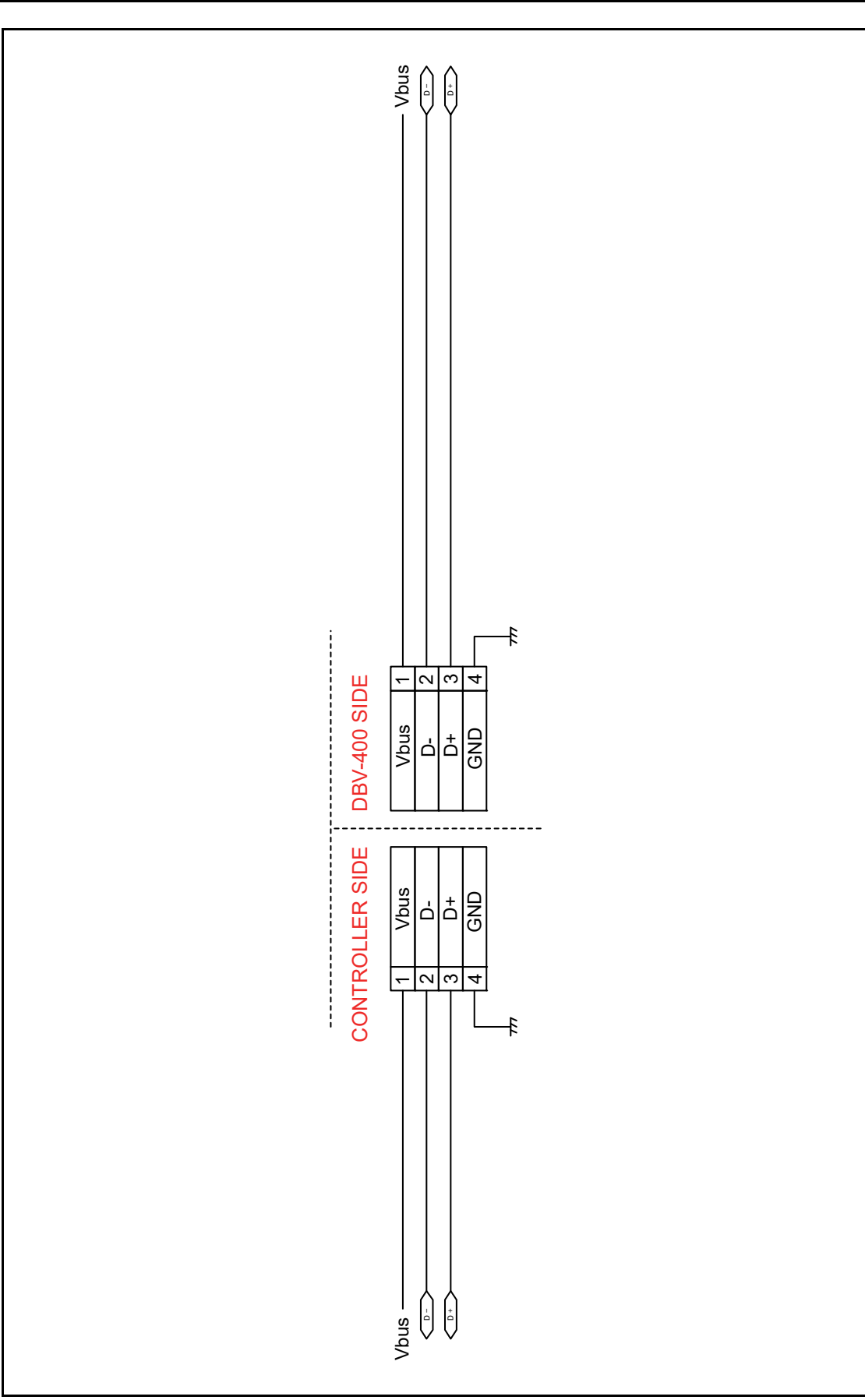

Figure 2-17 DBV-400 USB Interface Schematic Diagram

DBV™ Series DBV-400 Banknote Validator

THIS PAGE INTENTIONALLY LEFT BLANK

Operational Flowchart

Figure 2-18 depicts a typical DBV-400 Initialization Banknote acceptance flow process.

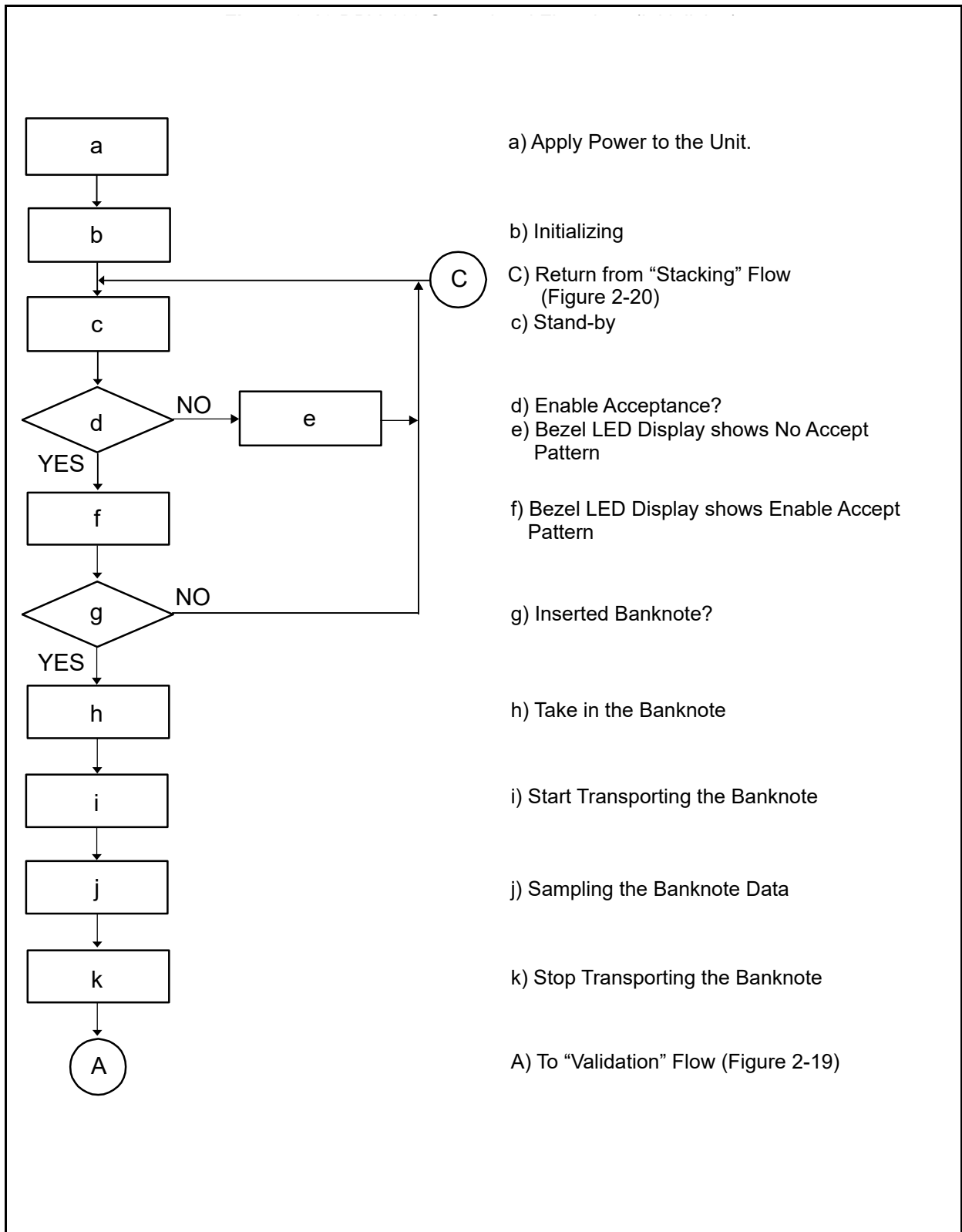

Figure 2-18 DBV-400 Operational Flowchart (Initializing)

Operational Flowchart (Continued 1)

Figure 2-19 depicts a typical DBV-400 Validation Banknote acceptance flow process.

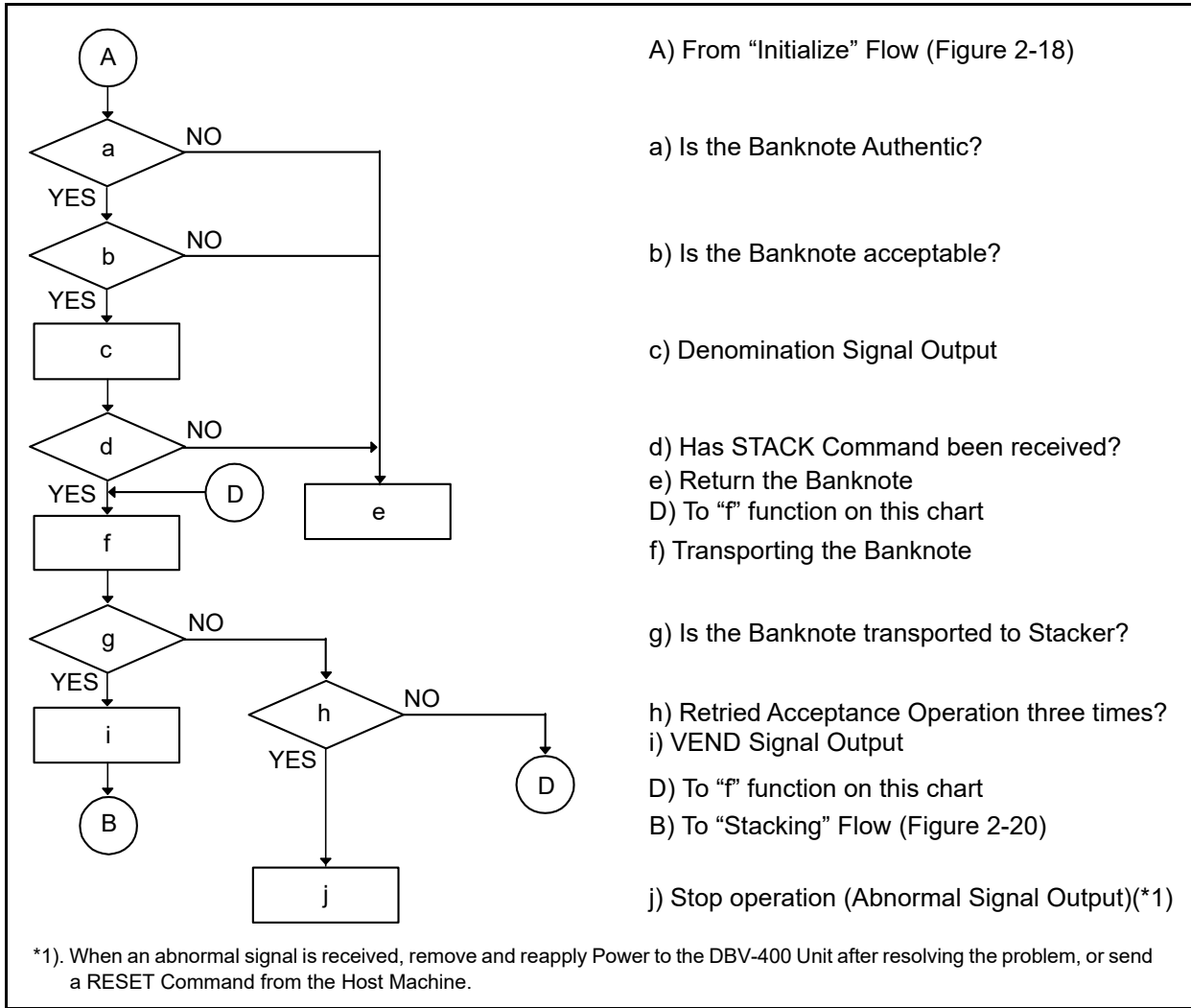

Figure 2-19 DBV-400 Operational Flowchart (Validation)

Figure 2-20 depicts a typical DBV-400 Stacking Banknote acceptance flow process.

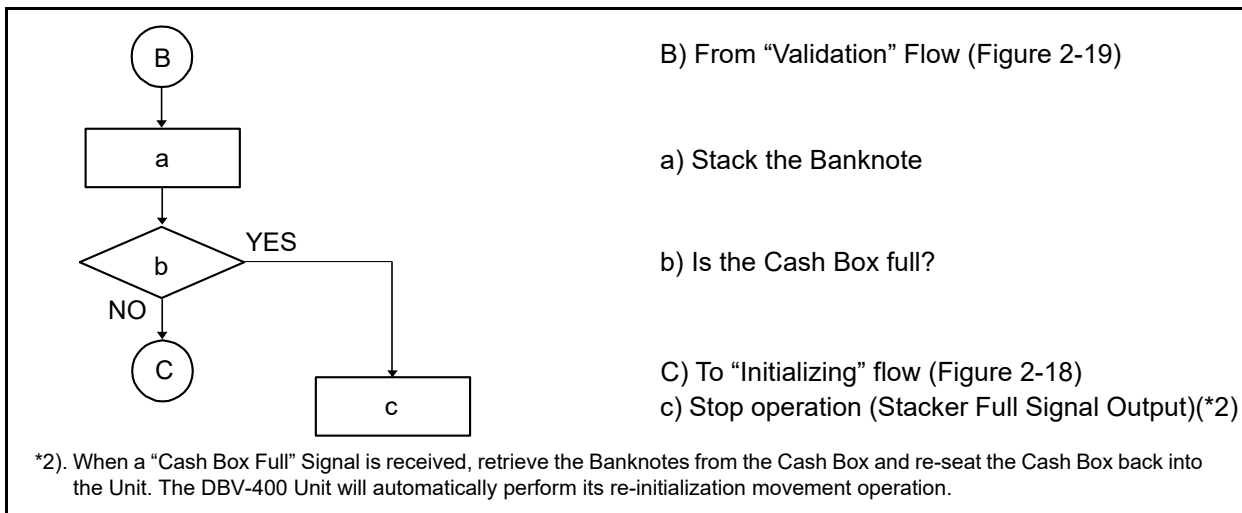

Figure 2-20 DBV-400 Operational Flowchart (Stacking)

DBV™ Series

DBV-400 Banknote Validator

Section 3

3 COMMUNICATIONS

This section was intentionally left out due to a Non-Disclosure Agreement requirement.

If this information is required, please contact the closest office location listed below:

Americas

JCM American

Phone: +1-702-651-0000

Fax: +1-702-644-5512

925 Pilot Road,
Las Vegas, NV 89119

E-mail: support@jcmglobal.com

Europe, Middle East, Africa & Russia

JCM Europe GmbH

Phone: +49-211-530-645-60

Fax: +49-211-530-645-85

Mündelheimer Weg 60 D-40472
Düsseldorf Germany

E-mail: support@jcmglobal.eu

UK & Ireland

JCM Europe (UK Office)

Phone: +44 (0) 190-837-7331

Fax: +44 (0) 190-837-7834

Luminous House, 300 South Row,
Milton Keynes MK9 2FR, United Kingdom

E-mail: support@jcmglobal.eu

Asia and Oceania

JCM American (Australia Office)

Phone: +61-2-9648-0811

Fax: +61-2-9647-1438

Unit 21, 8 Avenue of the Americas Newington,
NSW 2127 Australia

E-mail: Sales-AsiaPac@jcmglobal.com

JAPAN CASH MACHINE CO., LTD. (HQ)

Phone: +81-6-6703-8400

Fax: +81-6-6707-0348

2-3-15, Nishiwaki, Hirano-ku,
Osaka 547-0035 JAPAN

E-mail: Shohin@jcm-hq.co.jp

The JCM Website for all locations is:

<http://www.jcmglobal.com>

THIS PAGE INTENTIONALLY LEFT BLANK

DBV™ Series DBV-400 Banknote Validator

Section 4

4 DISASSEMBLY/REASSEMBLY

This section provides disassembly and reassembly instructions for the DBV™ Series DBV-400 Banknote Validator Unit. This section contains the following information:

- Tool Requirements
- CPU Circuit Board Removal
- Side Sensor Removal
- Motor Harness Assy. Removal
- Inside Validation Sensor Board Removal
- Outside Validation Sensor Board Removal
- Box Base Assy. Removal

Tool Requirements

The following tools will be required to perform the DBV-400 disassembly and reassembly:

- #1 & #2 Phillips Screwdrivers
- Main Frame Assy. Disassembling Tool (8 pieces)
- Cash Box Disassembling Tool (8 pieces)

CPU Circuit Board Removal

To remove the CPU Circuit Board, proceed as follows:

1. Press the Cash Box Release Button (Figure 4-1 a) and slightly pull the Cash Box upward and then out in the direction indicated by the arrow A.



NOTE: In the case of the optional Rear-Access Cash Box, pressing the Cash Box Release Button can be skipped. Pull the Rear-Access Cash Box upward and then out in the direction indicated by the arrow A.

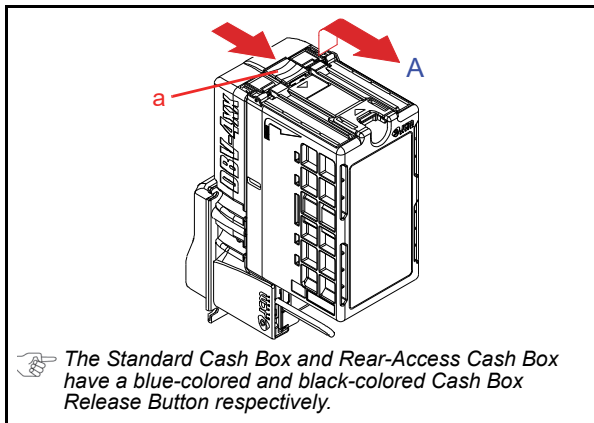

The Standard Cash Box and Rear-Access Cash Box have a blue-colored and black-colored Cash Box Release Button respectively.

Figure 4-1 Cash Box Removal

2. Remove the four (4) Mounting Screws (Figure 4-2 b₁ through b₄) securing the Bezel Unit (Figure 4-2 a) to the DBV-400 Main Unit. Then remove the Bezel Unit from the DBV-400 Main Unit.

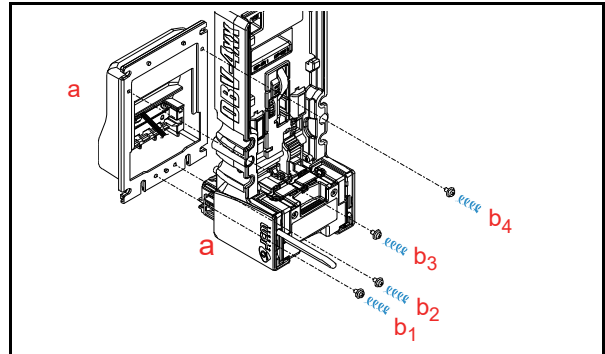

Figure 4-2 Bezel Unit Removal

3. Unplug the single (1) Connector (Figure 4-3 a).

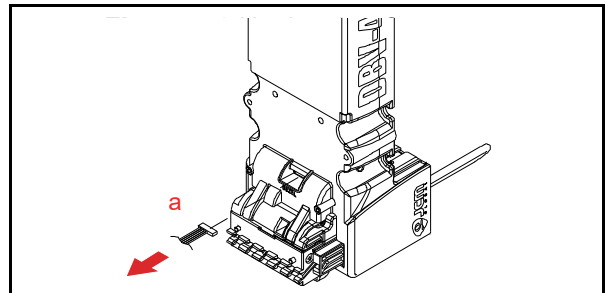

Figure 4-3 Unplugging Connector

4. Insert the Main Frame Assy. Disassembling Tool (8 pieces) into the indicated eight (8) spots (Figure 4-4 a₁ through a₈). Then remove the Main Frame Assy. (Figure 4-4 b) from the DBV-400 Frame Cover (Figure 4-4 c).

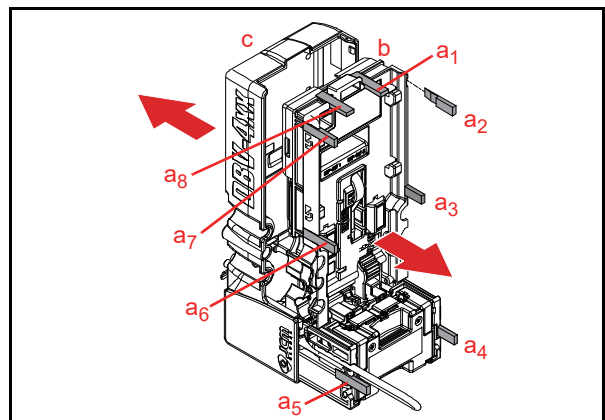

Figure 4-4 Main Frame Assy. Removal

5. Unplug the single (1) Connector (Figure 4-5 a).

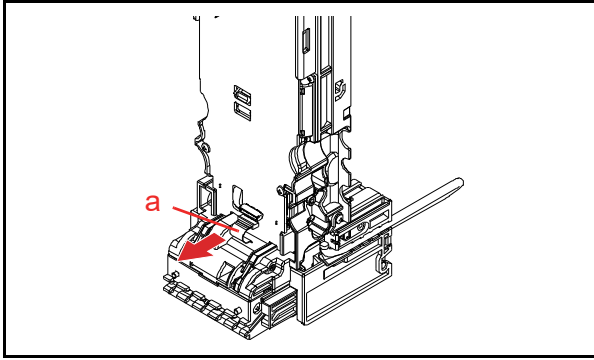

Figure 4-5 Unplugging Connector

6. Remove the four (4) Mounting Screws (Figure 4-6 b₁ through b₄) securing the CPU Circuit Board (Figure 4-6 a) to the Main Frame Assy. (Figure 4-6 d).
7. Unplug the five (5) Connectors (Figure 4-6 c₁ through c₅), and remove the CPU Circuit Board from Main Frame Assy. (Figure 4-6 d).

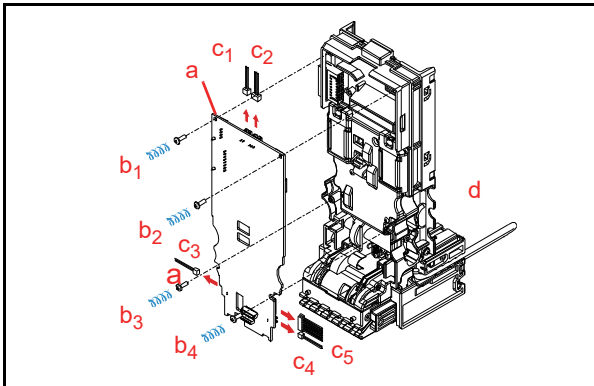

Figure 4-6 CPU Circuit Board Removal

Side Sensor Removal

To remove the Side Sensors, proceed as follows:

1. Unplug the two (2) Connectors (Figure 4-7 c₁ and c₂).
2. Remove the two (2) Mounting Screws (Figure 4-7 b₁ and b₂) securing the Side Sensors (Figure 4-7 a₁ and a₂), and remove the two (2) Side Sensors from the Main Frame Assy. (Figure 4-7 d).

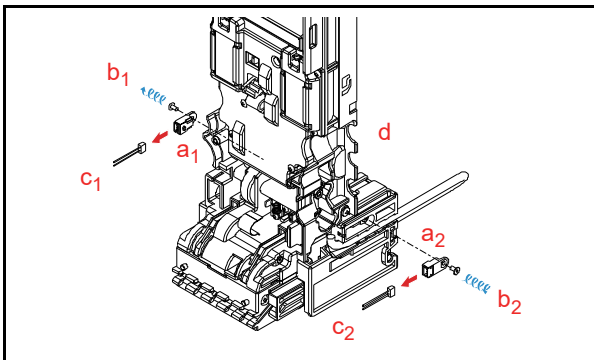

Figure 4-7 Side Sensor Removal

Motor Harness Assy. Removal

To remove the Motor Harness Assy., proceed as follows:

1. Remove the eight (8) Mounting Screws (Figure 4-8 b₁ and b₈) securing the Motor Gear Cover D4 (Figure 4-8 a), and remove the Motor Gear Cover D4 from the Main Frame Assy. (Figure 4-8 c).
2. Remove the Motor Harness Assy. (Figure 4-8 d) from the Main Frame Assy.

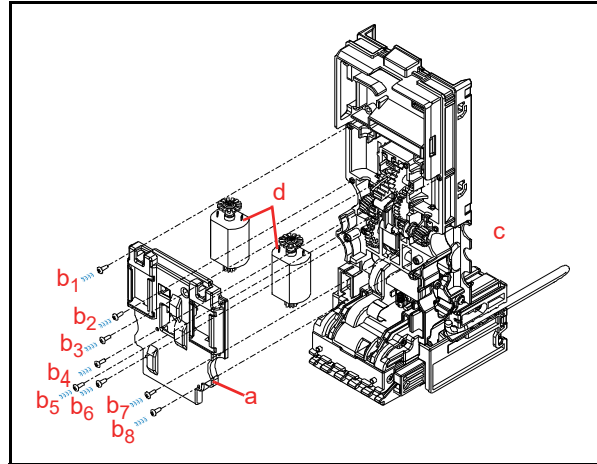

Figure 4-8 Motor Harness Assy. Removal

Inside Validation Sensor Board Removal

To remove the Inside Validation Sensor Board, proceed as follows:

1. Press the Validation Guide Open/Close Latch (Figure 4-9 a) upward and pull the Validation Guide (Figure 4-9 b) out of the Main Frame.

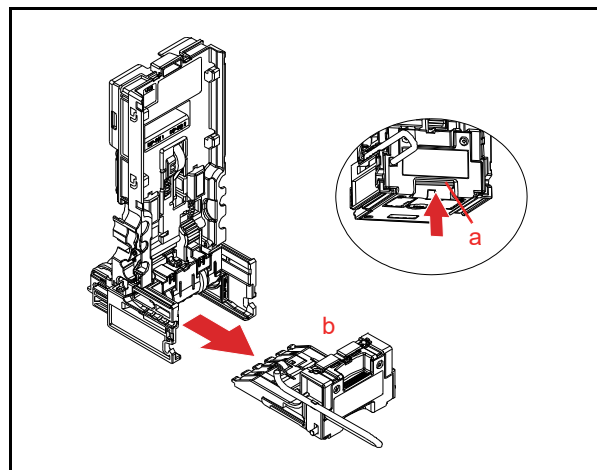

Figure 4-9 Validation Guide Removal

2. Remove the four (4) Mounting Screws (Figure 4-10 b₁ through b₄) securing the Validation Guide Cover Assy. (Figure 4-10 a), and separate the Validation Guide Cover Assy. from the Main Frame (Figure 4-10 c).

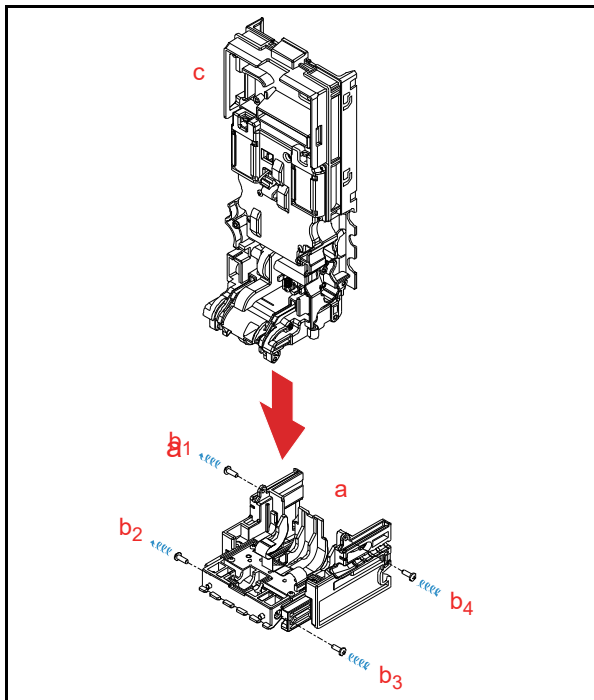

Figure 4-10 Validation Guide Removal

3. Unplug the single (1) Connector (Figure 4-11 a).
4. Remove the four (4) Mounting Screws (Figure 4-11 c₁ through c₄) securing the Inside Validation Sensor Board (Figure 4-11 b), and remove the Inside Validation Sensor Board from the Validation Guide Cover D4 (Figure 4-11 d).

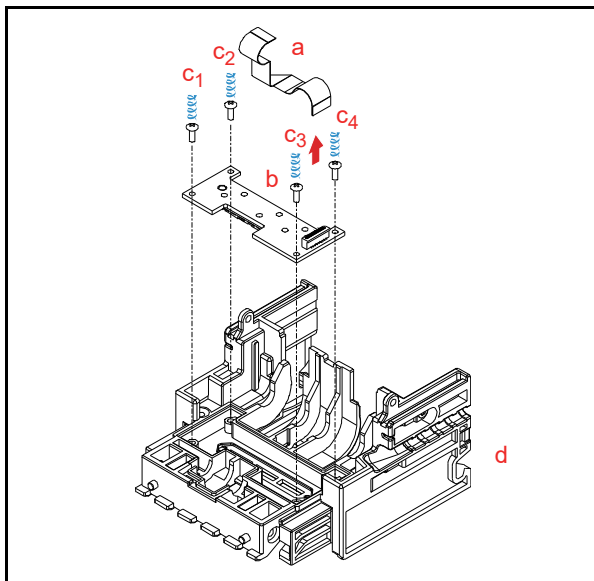

Figure 4-11 Inside Validation Sensor Board Removal

Outside Validation Sensor Board Removal

To remove the Outside Validation Sensor Board, proceed as follows:

1. Remove the six (6) Mounting Screws (Figure 4-12 b₁ through b₆) securing the Outside Guide Cover (Figure 4-12 a) to the Validation Guide (Figure 4-12 c).

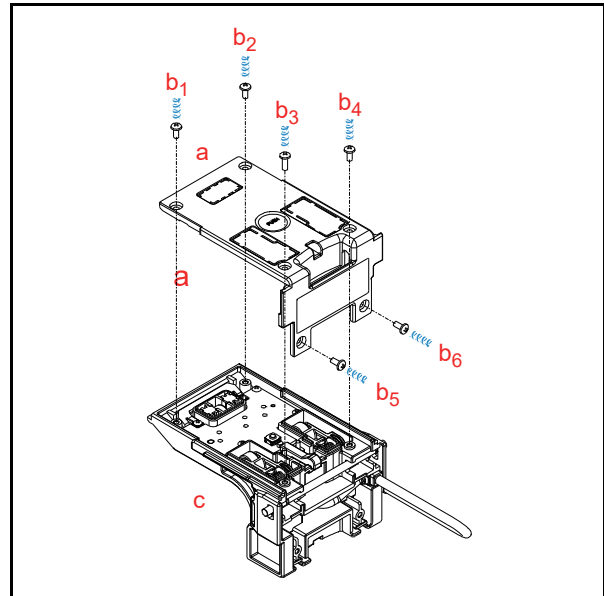

Figure 4-12 Outside Guide Cover Removal

2. Unplug the single (1) Connector (Figure 4-13 a).
3. Remove the four (4) Mounting Screws (Figure 4-13 b₁ and b₄) securing the Outside Sensor Board (Figure 4-13 c), and remove the Outside Validation Sensor Board from the Validation Guide (Figure 4-13 d).

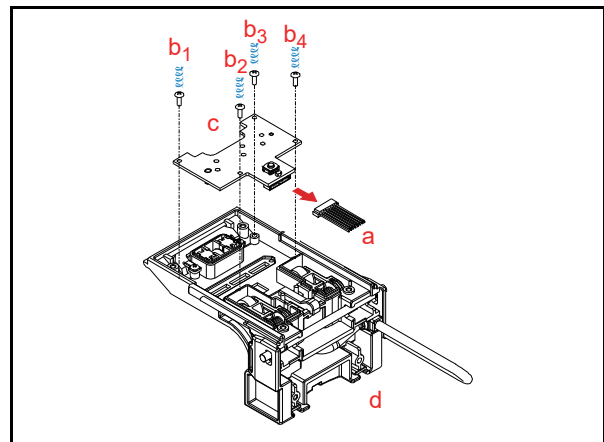



Figure 4-13 Outside Validation Sensor Board Removal

Box Base Assy. Removal

To remove the Box Base Assy., proceed as follows:

1. Insert the Cash Box Disassembling Tool (8 pieces) into the indicated eight (8) spots (Figure 4-14 a₁ through a₈) to unlock the tabs on the Box Base Assembly (Figure 4-14 b).

 **NOTE:** To unlock each tab, make sure the square-cut beveled surface of the Cash Box Disassembling Tool (refer to Figure 4-14 c) faces outward, with the flat surface facing the side of the Box Base Assembly.

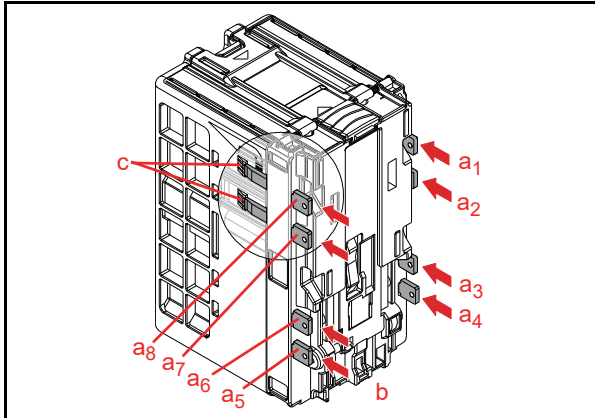

Figure 4-14 Box Base Assy. Removal 1

2. Remove the Box Base Assy. (Figure 4-15 a) from the Box Frame D-4 (Figure 4-15 b).

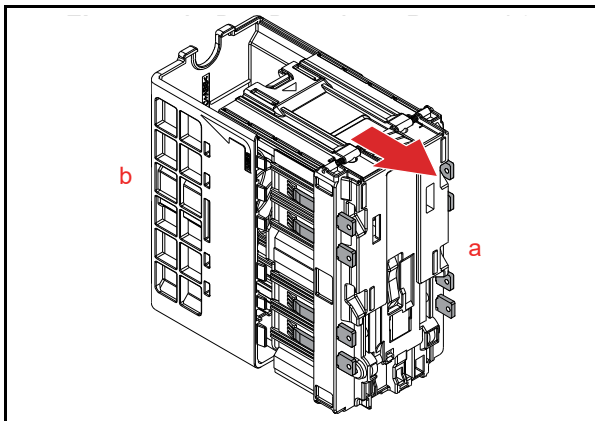

Figure 4-15 Box Base Assy. Removal 2

DBV™ Series

DBV-400 Banknote Validator

Section 5

5 WIRING DIAGRAMS

This chapter provides for the DBV™ Series DBV-400 Banknote Validator Unit Wiring Diagrams for the following items:

- System Wiring Diagram

System Wiring Diagram

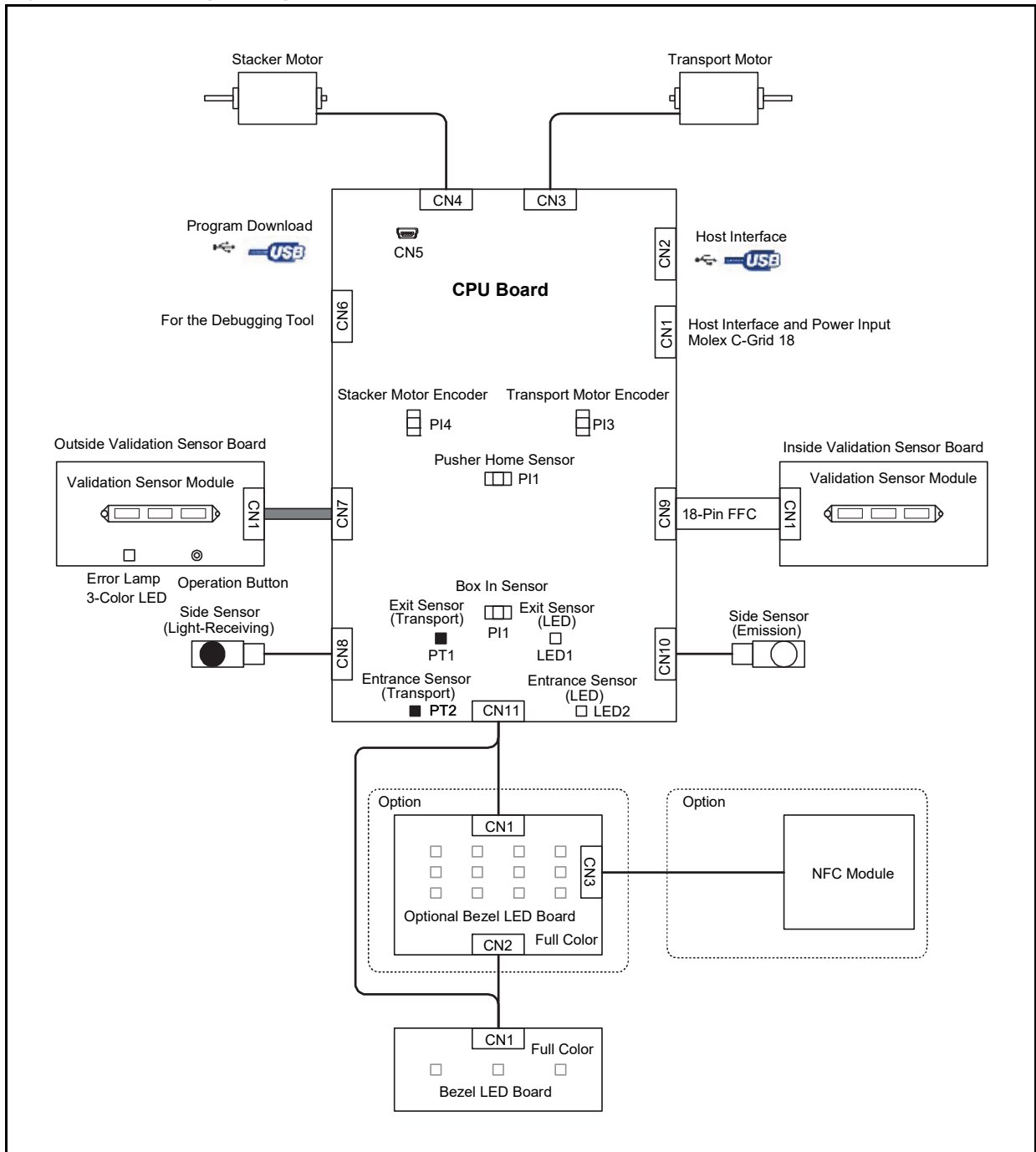

Figure 5-1 DBV-400 System Wiring Diagram

THIS PAGE INTENTIONALLY LEFT BLANK

DBV™ Series

DBV-400 Banknote Validator

Section 6

6 CALIBRATION AND TESTING

This section provides Calibration and Performance Testing instructions for the DBV™ Series DBV-400 Banknote Validator Unit and contains the following information:

- Tool Requirement
- Installation Procedures
- JCM Tool Suite Standard Edition Mode
- Download Procedures
- Calibration
- Performance Tests

Tool Requirement

See “Component Names” on page 1-5 for detail connector locations.

With Reference Paper and a PC

Figure 6-1 and Figure 6-2 identify the Tools and equipment interconnects necessary to install and/or download the Application Software, USB driver and Firmware Software, to calibrate the DBV-400 Unit away from its Host Machine, and to perform a DBV-400 Performance Test using a PC.

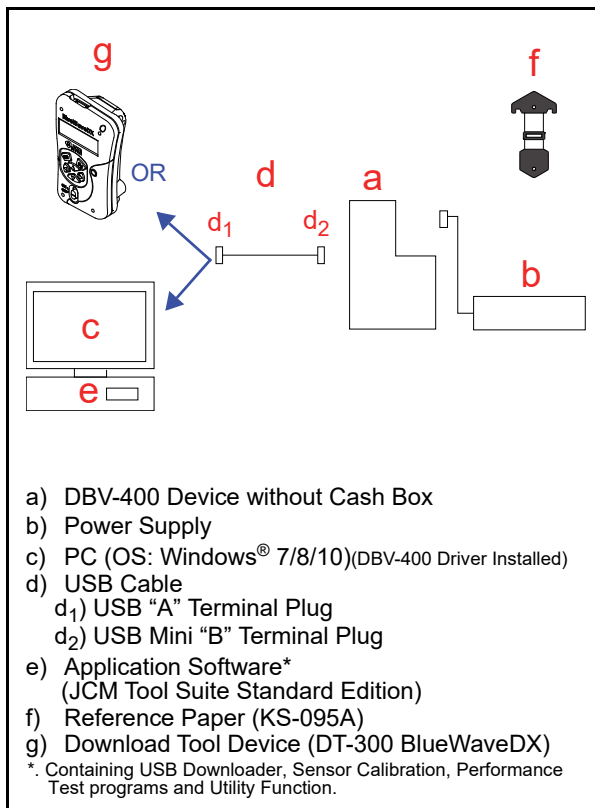

Figure 6-1 Tool and Harness Connections 1

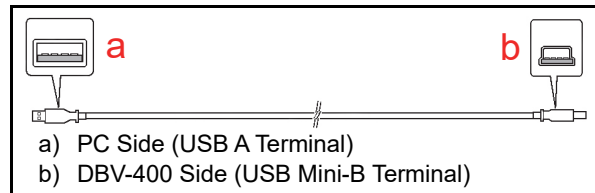

Figure 6-2 USB Cable Type Requirement

Without a PC

Figure 6-3 identifies the Tools and equipment interconnects necessary to perform a DBV-400 Performance Test without a PC.

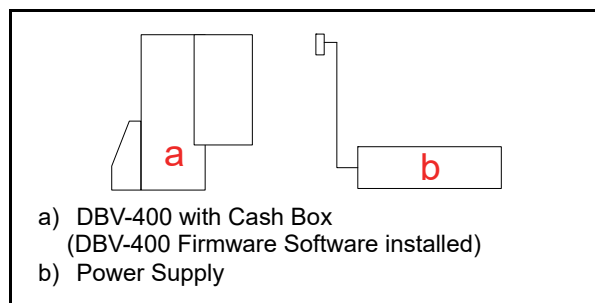

Figure 6-3 Tool and Harness Connections 2

Power Supply

Either a 12 - 24V DC Power Supply for DBV-400 Series Units or a UAC Converter is required to perform the following procedures:

- Sensor Calibration
- Downloading Software to Flash Memory
- Communication between the DBV-400 Unit and the PC

If the UAC Converter shown in Table A-6 on page A-8 is preferred, refer to JCM UAC Device Operational Instructions (Part No. 960-100194R) for details on its use.

Installation Procedures

This section provides the JCM Tool Suite Standard Edition installation procedure.

Application Software Installation

Perform the following steps to install the “JCM Tool Suite Standard Edition” Application Software (Refer to Figure 6-1 “Tool and Harness Connections 1” and Figure 6-2 “USB Cable Type Requirement” for tool requirement).

1. Copy the “JCMToolSuiteStandardEdition.zip” Application Software and extract it onto the Desktop.
2. Open the third layer of the extracted Folder and double-click on “Setup.exe”(Figure 6-4 a).

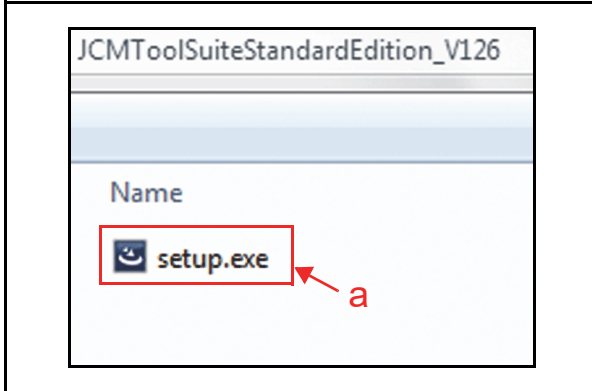

Figure 6-4 Setup.exe File Location

The “JCM Tool Suite Standard Edition - Install Shield Wizard” Screen shown in Figure 6-5 will appear.

3. Click the “Next>” Button (Figure 6-5 a).

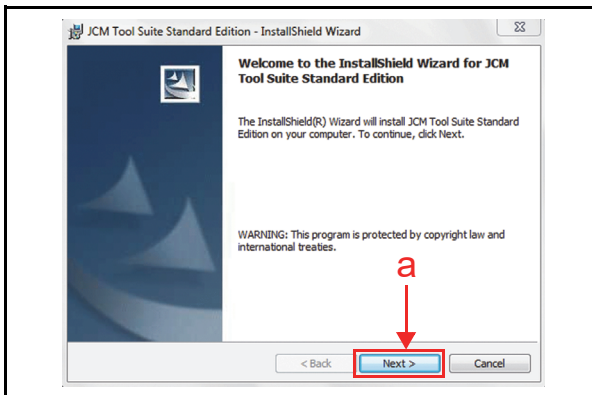

Figure 6-5 InstallShield Wizard Screen

4. Click the “Next>” Screen Button (Figure 6-6 a) when the “Destination Folder” Screen shown in Figure 6-6 appears.

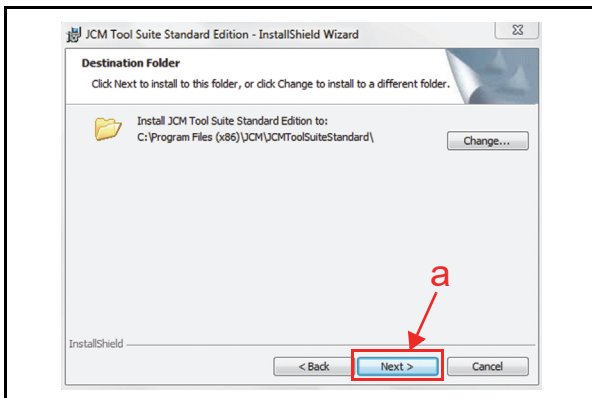

Figure 6-6 Destination Folder Screen

5. When the “Ready to Install the Program” Screen appears, click “Anyone who uses this computer (all users)” (Figure 6-7 a), and then click on the “Install” Screen Button (Figure 6-7 b) to start the installation.

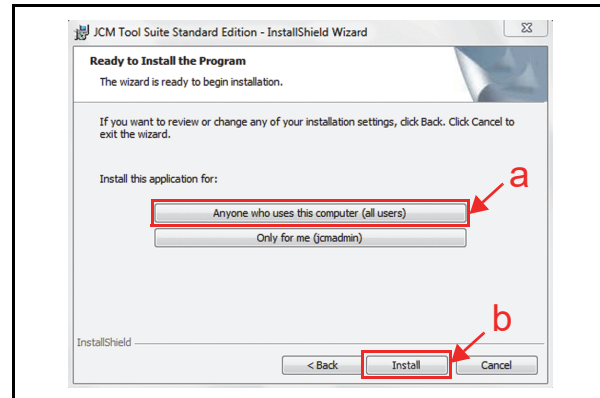

Figure 6-7 Current Settings Confirmation

6. Once installation is complete, the “InstallShield Wizard Completed” Screen shown in Figure 6-8 will appear. Click on the “Finish” Screen Button (Figure 6-8 a) to end the installation process.

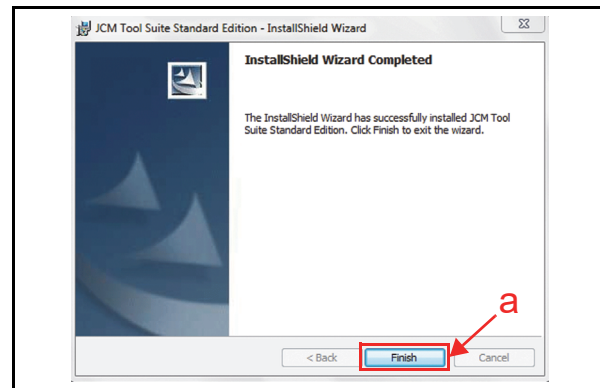



Figure 6-8 Installation Completion Screen

This completes the “JCM Tool Suite Standard Edition” installation procedure.

Driver Installation Procedure

DBV-400 USB Drivers need to be installed on the PC before the JCM Tool Suite Standard Edition can be used. To install the DBV-400 Software Driver, proceed as follows:

 **NOTE:** USB Drivers are automatically loaded on the PC when JCM Tool Suite is installed. Use this procedure if the USB Drivers need to be installed manually.

1. Copy the DBV-400 Driver (DBV-400 USB driver-win*.inf) into the desired PC Folder.
2. Connect the USB Cable to the DBV-400 Unit (refer to Figure 6-1 and Figure 6-2 for the Tool Requirements and Harness Connector locations).
3. When the Device Driver Installation Wizard Screen (Figure 6-9) appears, click on the “Next>” Screen Button (Figure 6-9 a) to install the driver for the DBV-400 Unit.

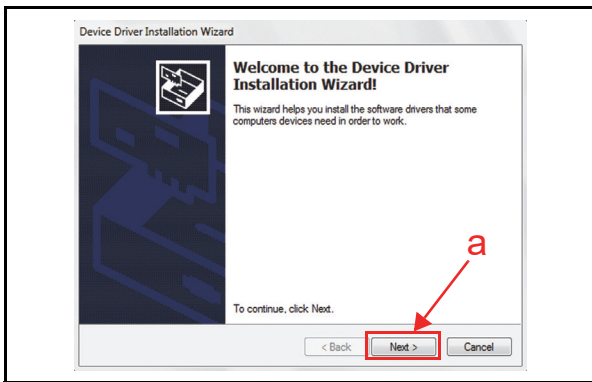

Figure 6-9 Hardware Update Wizard Screen 1

4. When the USB Driver Installation is complete, the “Completing the Device Driver Installation Wizard” Screen will appear as shown in Figure 6-10. Click on the “Finish” Screen Button (Figure 6-10 a) to close the Screen.

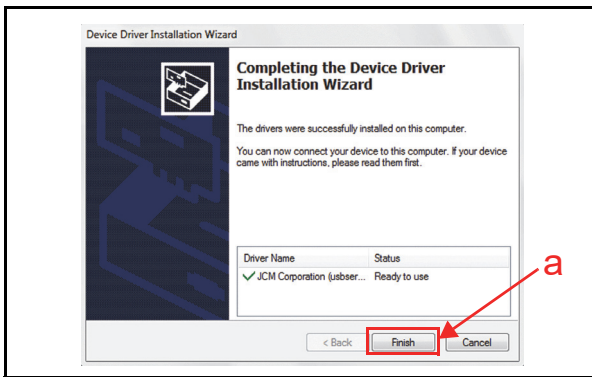

Figure 6-10 Hardware Update Wizard Screen 2

 **NOTE:** If the Windows Security Screen appears, select “Install this Driver Software (I)” to proceed.

This completes the DBV-400 USB Driver Software installation procedure.

JCM Tool Suite Standard Edition Mode

The following two (2) mode feature types exist in the “JCM Tool Suite Standard Edition” package:

- Normal Mode
- Test Mode

“Normal Mode” is a mode designed to provide the DBV-400 Operating Software to be downloaded. The “Service Mode” contains three (3) available choices (shown in Figure 6-11a) as follows:

- **Download** (for downloading software)
- **Statistics** (for observing log data)
- **Event Log View** (for confirming Event Log)

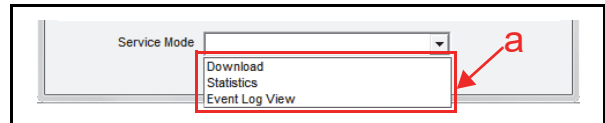

Figure 6-11 Normal Mode Selection

“Test Mode” is a mode designed to perform DBV-400 Calibration and Performance Testing. The “Service Mode” contains five (5) available choices in its Pull-down Menu (Figure 6-12 a) as follows:

- **Download** (for downloading software)
- **Statistics** (for observing log data)
- **Sensor Adjustment** (for calibration)
- **Performance Test** (for Performance Testing)
- **Event Log View** (for confirming Event Log)

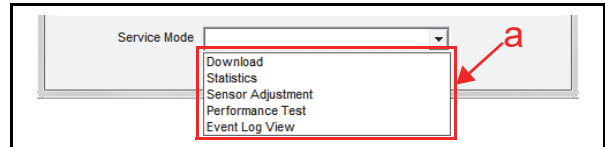



Figure 6-12 Test Mode Selection

Download Procedures

The following two (2) procedures are available to download the DBV-400 Software Program:

 **NOTE:** For the download procedures with a DT-300 BlueWaveDX, refer to the JCM Global® BlueWave™ DT-300 Integration Guide and Operator Guide.

- The DBV-400 Software Program is loaded on the Unit (Normal)
- The DBV-400 Software Program is not loaded on the Unit (e.g., after replacing the CPU Board)

Software Program Download

To download the DBV-400 Software Program, proceed as follows:

1. Remove electrical power from the DBV-400 Unit.
2. When upgrading the Software in Normal condition, set all of the 8-position DIP Switches of DIP Switch Block 1 (DIP SW1) to OFF (Figure 6-13).

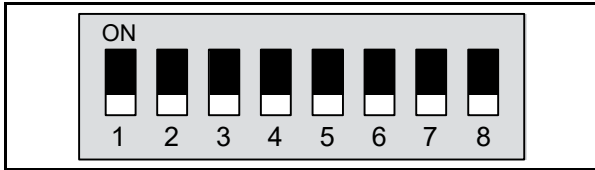

Figure 6-13 Normal Upgrade Setting

When downloading to a Unit (Software not previously installed), set DIP Switch Block 1 (DIP SW1) Switches #6, #7 and #8 to ON (Figure 6-14).



Figure 6-14 Initial Download Setting

3. Connect the USB Port on the DBV-400 Unit to the PC (Refer to Figure 6-1 and Figure 6-2 for Tool Requirements and Harness Connector locations).
4. Apply electrical power to the DBV-400 Unit.
5. Launch the “JCM Tool Suite Standard Edition” Application. The Screen shown in Figure 6-15 will appear when the application opens.

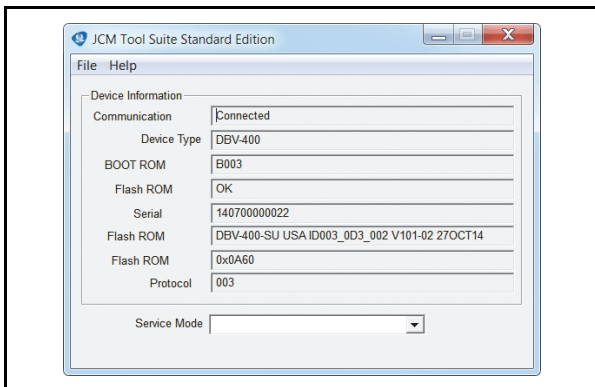

Figure 6-15 Normal Upgrade Screen

When downloading the Software Program to the

DBV-400 Unit for the first time, the Device Information will not appear (Figure 6-16).

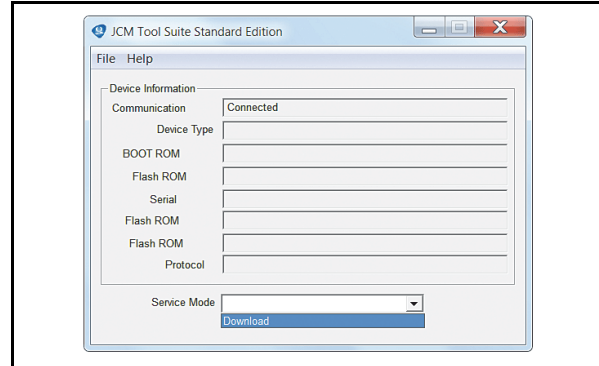

Figure 6-16 Initial Download Screen

6. Click and hold-down the “Service Mode” Pull-Down Menu and select “Download” (Figure 6-17 a) from the Menu. The selected Field will highlight Blue, and the Bezel LED will flash at a Green Color rate.

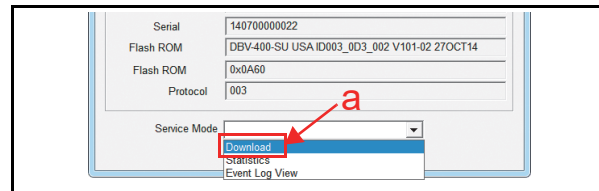

Figure 6-17 JCM Tool Suite Standard Edition Screen Pull-Down Menu

7. When “Download” is selected, the “JCM Downloader Suite Edition Version X.XX” will automatically begin functioning, and the Screen shown in Figure 6-18 will appear. Click on the “Browse” Screen Button (Figure 6-18 a).

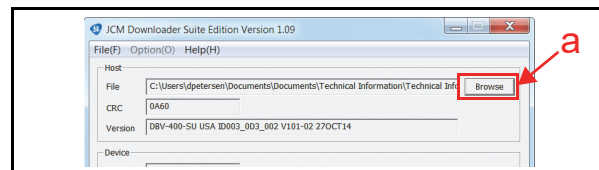

Figure 6-18 Browse Screen Button Location

8. Click the appropriate DBV-400 Software Program Version shown in the Download File Screen

(Figure 6-19 a), and then click on the “Open” Screen Button (Figure 6-19 b).

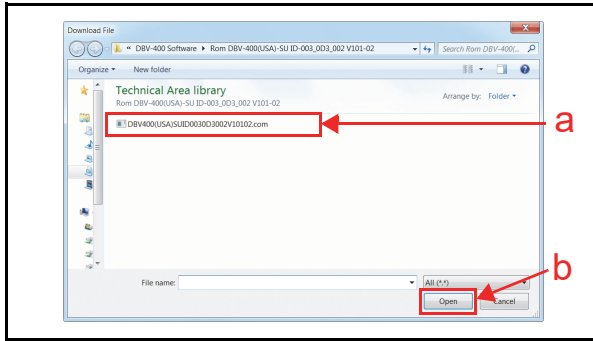

Figure 6-19 DBV-400 Software Program Selection

NOTE: Select the correct DBV-400 Firmware for the Country desired.

- When the “JCM Downloader Suite” Screen re-appears, click the “Download” Screen Button (Figure 6-20 a) to begin the Software download into the DBV-400 Unit. The Download Screen will display a Progress Bar during the download operation (Figure 6-20 b), and a Blue Text Line below the Download Screen Button will display the download Percentage as “Downloading : XX%” (Figure 6-20 c). The Bezel LED will flash a Green Color rate at a longer interval during this operation.

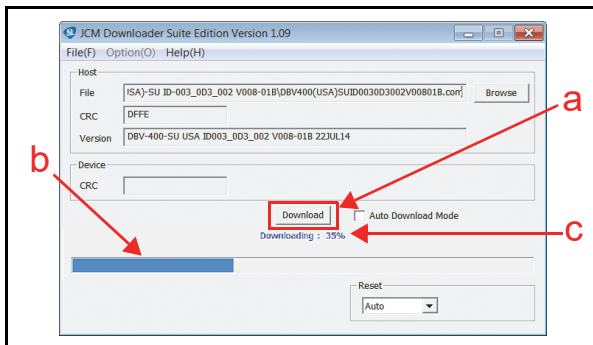

Figure 6-20 Download Progress Screen 1

- When the download is complete, the “Download Success. Reset Done. Waiting for USB Cable Disconnection.” Status Line will appear (Figure 6-21 a). Confirm that the Host Checksum (CRC) value and the Device Checksum (CRC) value match identically (Figure 6-21 b).

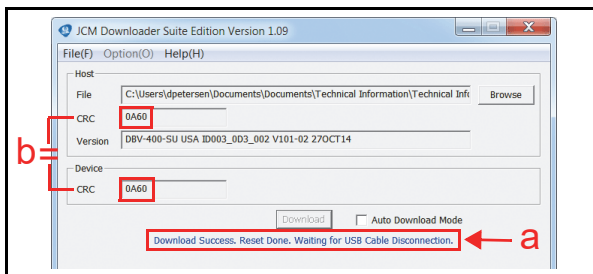

Figure 6-21 Download Completed Screen 1

This completes the DBV-400 Software Downloading Procedures.

Calibration

This section provides instructions for performing a calibration of the DBV-400 Sensors.

NOTE: Refer to Figure 6-1 and Figure 6-2 for the necessary Tool and Harness Connections and USB Cable Type Requirements respectively.

When to Calibrate

Calibration should be performed when any of the following conditions occur:

- When removing one of the Circuit Boards;
- When replacing one of the Circuit Boards;
- When dirt adheres to the Sensors (See “Sensor and Roller Cleaning Procedure” on page 2-11);
- When the Banknote Acceptance Rate becomes drastically degraded.

Placing the KS-095A Reference Paper

This section provides information regarding the KS-095A Reference Paper’s settings and uses.

NOTE: Do not bend the Holders (Figure 6-22 a) or touch the Paper Surfaces on either side of the KS-095A Reference Paper (Figure 6-22 b).

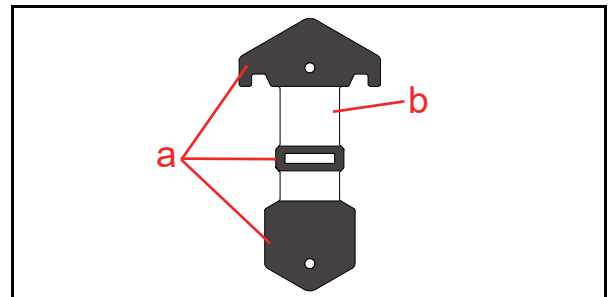

Figure 6-22 KS-095A Reference Paper

Perform the following steps to properly place the KS-095A Calibration Reference Paper into the DBV-400 Unit:

- Press the Cash Box Release Button (Figure 6-23 a) in the direction indicated by the blue arrow. Then pull slightly upward and out in the direction indicated by the red arrow A, and remove the Cash Box (Figure 6-23 b).

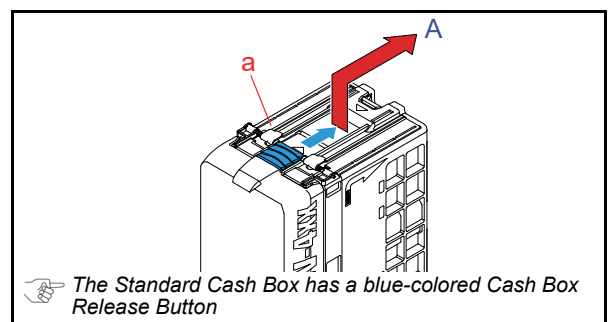

Figure 6-23 Placing KS-095A Reference Paper 1 (Standard Cash Box)

In the case of the optional Rear-Access Cash Box, pressing the Cash Box Release Button (Figure 6-24 a) can be skipped. Pull the Rear-Access Cash Box upward (Figure 6-24 ①) to unlock the Box Latch and then out in the direction Figure 6-24 ②.

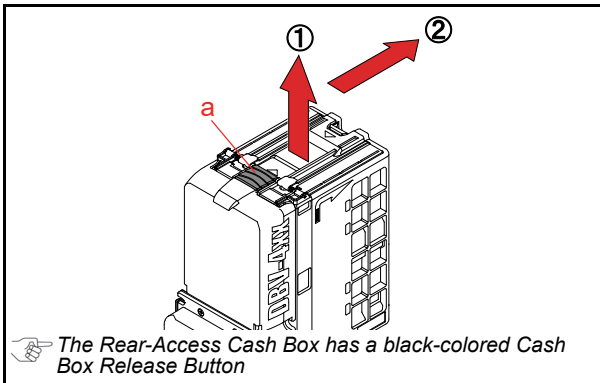

Figure 6-24 Placing KS-095A Reference Paper 1 (Rear-Access Cash Box)

2. Press the Validation Guide Open/Close Latch (Figure 6-25 a) upward, then pull the Validation Guide (Figure 6-25 b) out of the DBV-400 Unit.

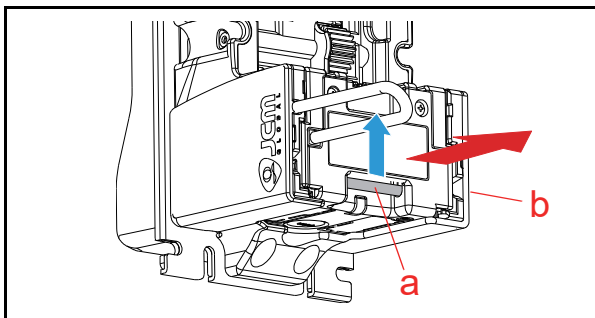

Figure 6-25 Placing KS-095A Reference Paper 2

3. Remove Guide Chip A (Figure 6-26 a) and Guide Chip B (Figure 6-26 b) from the DBV-400 Unit.

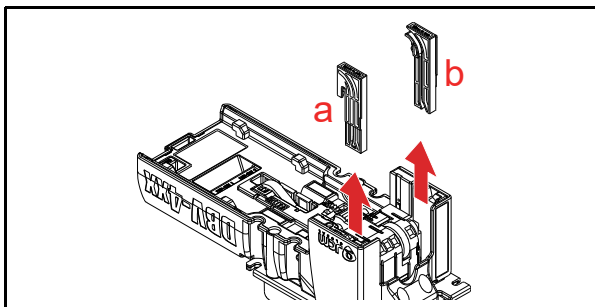

Figure 6-26 Placing KS-095A Reference Paper 3

4. Insert the small end of the KS-095A Reference Paper (Figure 6-27 a) through the backside of the DBV-400 Banknote Path. The small end will come out of the Bezel's Banknote Insertion Slot (Figure 6-27 b).

5. Hook the KS-095A Reference Paper Tabs into both sides of the Cut-out Space on the DBV-400 Unit (Figure 6-27 c).

NOTE: Make sure that the Reference Paper Tabs are firmly hooked into the Cut-out Space.

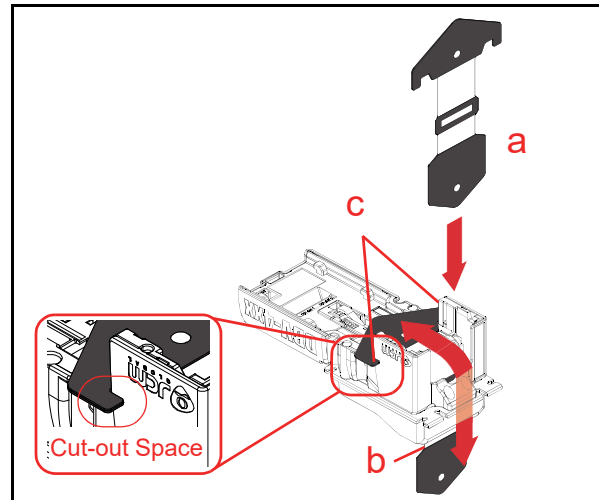

Figure 6-27 Placing KS-095A Reference Paper 4

6. Place the KS-095A Reference Paper (Figure 6-28 b) in the center of the Transport Path to ensure the Inside Sensors are covered by the Reference Paper as shown in Figure 6-28a.

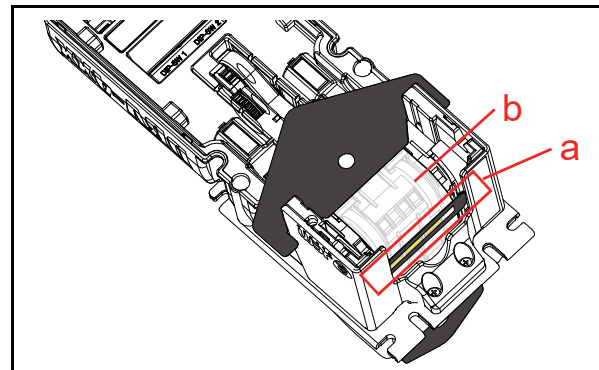

Figure 6-28 Placing KS-095A Reference Paper 5

7. Firmly set the Validation Guide (Figure 6-29 a) while adjusting the KS-095A Reference Paper (Figure 6-29 b) placement location until the Guide “clicks” into place, and ensure that it is tightly locked.

8. Pull the KS-095A Reference Paper (Figure 6-29 **b**) just slightly in the direction indicated by the red arrow **A** until the Reference Paper is taut.

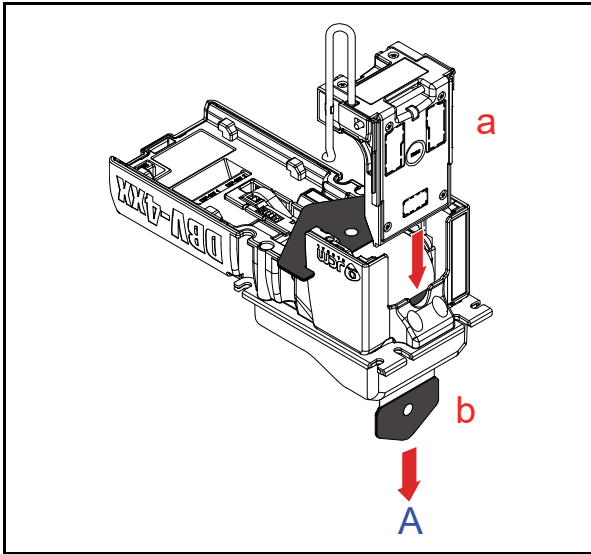

Figure 6-29 Placing KS-095A Reference Paper 6



NOTE: Make sure that the Guide Chip A (Figure 6-26 **a**) and Guide Chip B (Figure 6-26 **b**) are set back in the DBV-400 Unit after calibration is complete.

Calibration Preparation

Perform the following steps to prepare the DBV-400 for Sensor Calibration:

1. Remove electrical power from the DBV-400 Unit.
2. Remove the Cash Box from the DBV-400 Unit.
3. Connect the USB Cable to the USB Connector for maintenance (Refer to Figure 6-1 and Figure 6-2 for the Tool Requirements and Harness Connector locations).
4. Set DIP Switch #8 to ON (Figure 6-30).

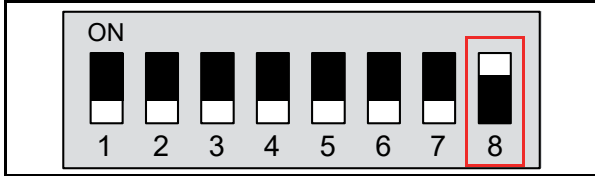

Figure 6-30 DIP SW1 Setting

5. Apply electrical power to the DBV-400 Unit. The Bezel LED will flash a Green color rate.
6. Launch the “JCM Tool Suite Standard Edition” Application (Figure 6-31), then click the “Service Mode” Pull-Down Menu, and select “Sensor Adjustment” (Figure 6-31 a).

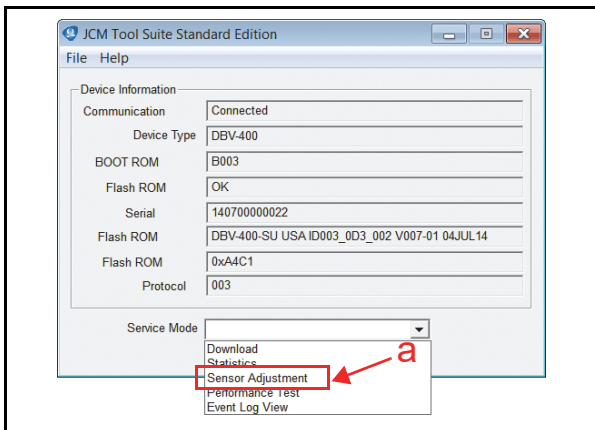

Figure 6-31 Launching JCM Tool Suite Standard Edition/Sensor Adjustment Selection

7. Confirm that the Sensor Calibration Program Screen appears (Figure 6-32).

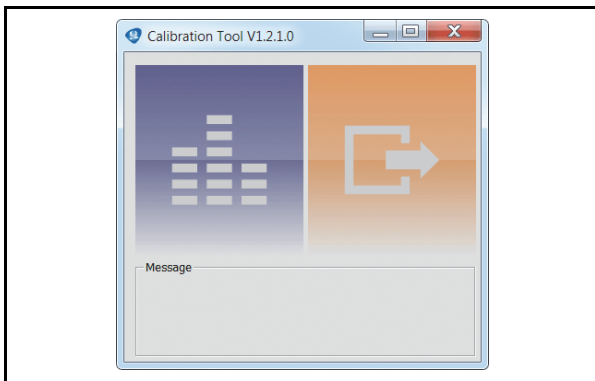

Figure 6-32 Sensor Calibration Screen 1

Sensor Calibration

To calibrate the DBV-400 sensors, proceed as follows:

1. Click the “Sensor Calibration” button (Figure 6-33 a).

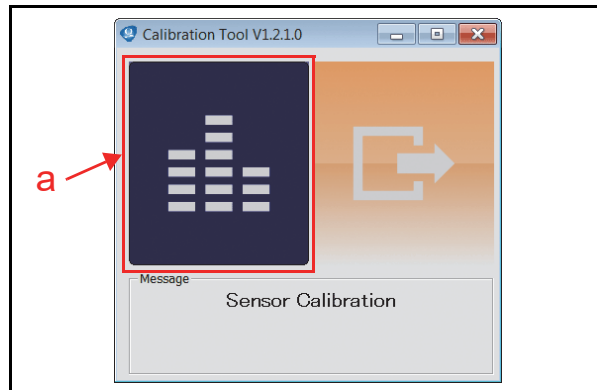

Figure 6-33 Sensor Calibration Screen 2

2. Confirm that the “DBV-400 SENSOR CALIBRATION” Screen appears (Figure 6-34).
3. Make sure the Validation Guide Open/Close Latch (refer to Figure 1-4 n) is Closed (securely latched in the Down position on both the left and right sides). Then click the “Start” button (Figure 6-34 a) to begin the non-paper calibration.

NOTE: Make sure there are no foreign objects in the Transport Path.

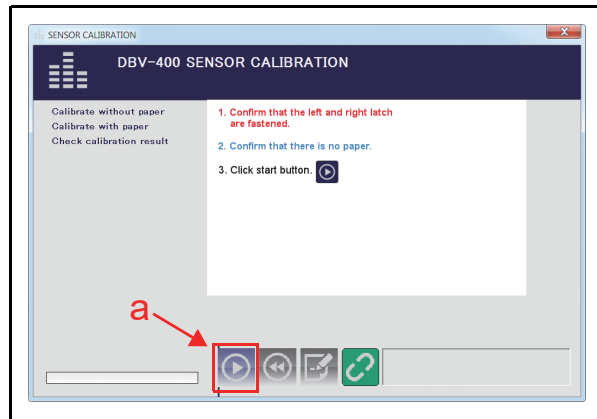

Figure 6-34 Non-Paper Calibration Screen

4. Confirm that the non-paper calibration was completed with a check mark (Figure 6-35 a) appearing next to the “Calibration without paper” text line.

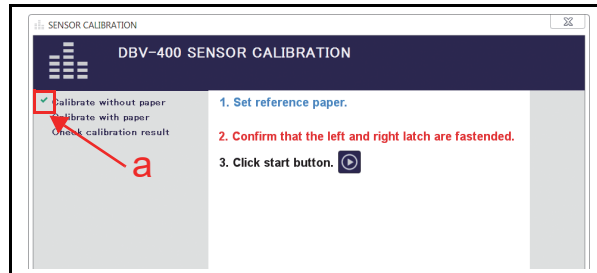



Figure 6-35 Non-Paper Calibration Completion

- The “Set a reference paper and click the start button.” message dialogue box will appear. Place the KS-095A Reference Paper into the DBV-400 Device and insert the Validation Guide, then click the “OK” button (Figure 6-36 a).

 **NOTE:** Refer to Step 1 of “Placing the KS-095A Reference Paper” on page 6-5.

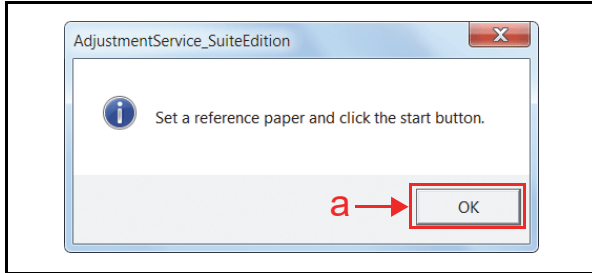

Figure 6-36 Placing Reference Paper Message

- Click the “Start” button (Figure 6-37 a) to begin the Reference Paper Calibration.

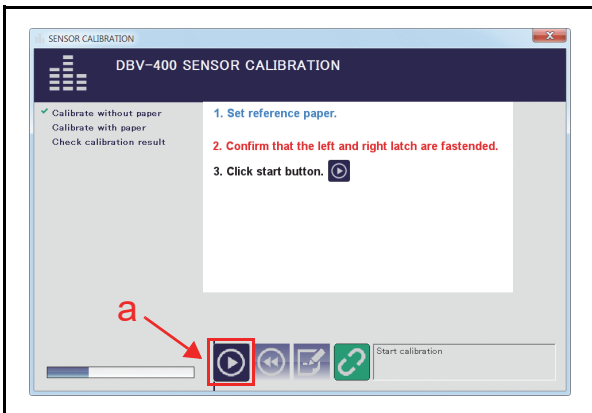



Figure 6-37 Reference Paper Calibration

- Confirm that “Calibration with paper” calibration is completed with a check mark (Figure 6-39 a) next to the “Calibration with paper” text line.
- Confirm that the “Remove a reference paper and click start button.” message dialogue box appears. Remove the KS-095A Reference Paper and click the “OK” button (Figure 6-38 a).

 **NOTE:** Remove the Validation Guide (refer to Figure 6-25 on page 6-6) before removing a reference paper.

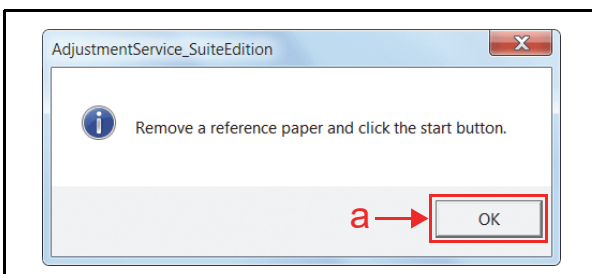

Figure 6-38 Removing Reference Paper Message

- Confirm that the Validation Guide is locked firmly, then click “Start” button (Figure 6-39 b) to begin the second Non-paper Calibration.

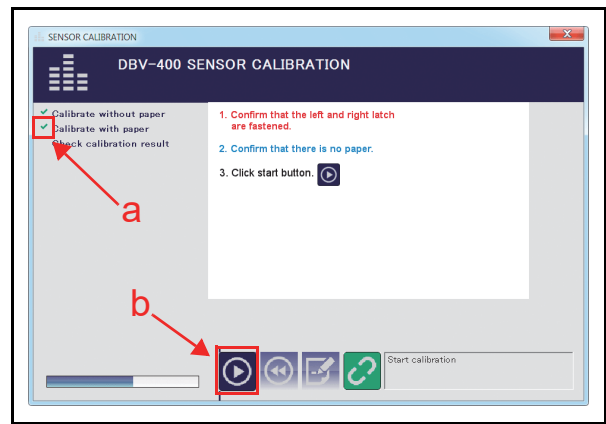

Figure 6-39 Second Non-Paper Calibration

- When the second Non-paper Calibration is completed, the “Maintenance Calibration Tool” dialogue screen appears to change the Serial Number. When using the default Serial Number, click the “No” button (Figure 6-40 a) to finish the calibration.

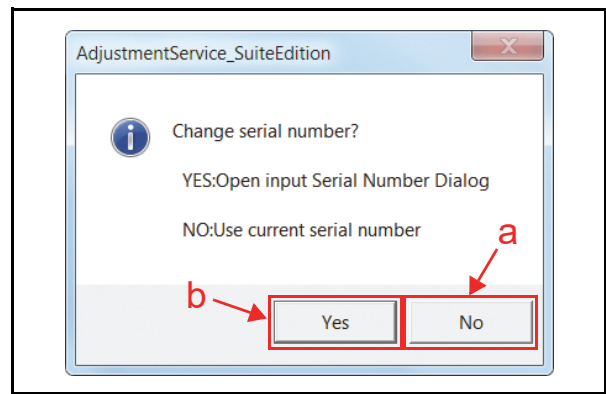



Figure 6-40 Serial Number Change Dialogue

To change the Serial Number, click the “YES” button (Figure 6-40 b) and type the desired 10-digit (Maximum: 12-digit) Serial Number in the Serial No. text box (Figure 6-41 a) on the SERIAL NUMBER SETTING Screen. Then click the “OK” button (Figure 6-41 b).

 **NOTE:** When clicking the “CANCEL” button (Figure 6-41 c), the Serial Number change is not saved.

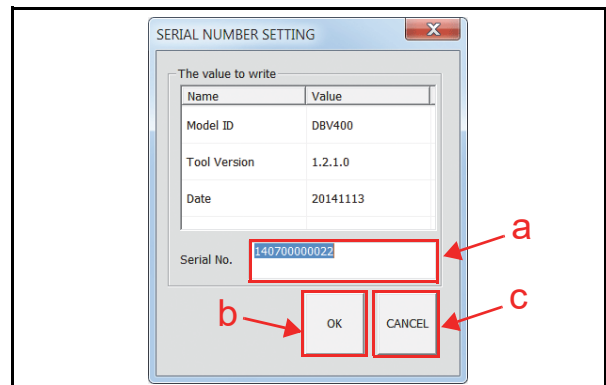



Figure 6-41 Serial Number Setting

- Once the Serial Number Setting is completed, Calibration Data will be written on the EEPROM. When the data writing finishes normally, the “Calibration Succeeded.” message dialogue box appears. Click the “OK”  button (Figure 6-42 a) to close the message dialogue box.

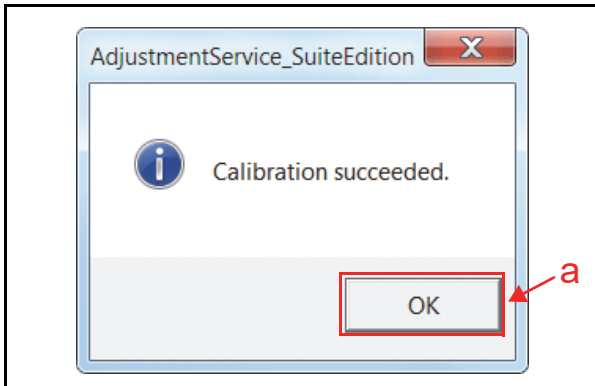



Figure 6-42 Calibration Succeeded Message

- Click the “Start”  button (Figure 6-43 a) to save the calibration settings.

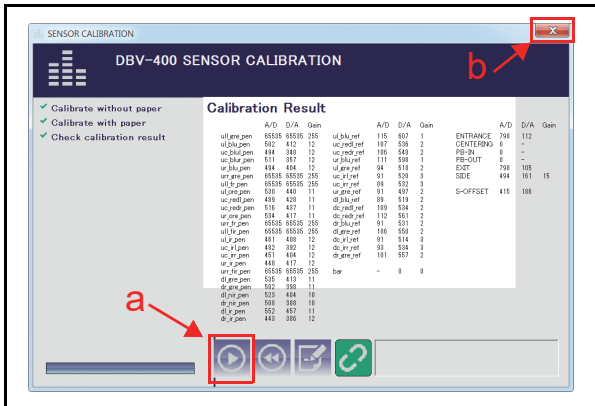

Figure 6-43 Calibration Result

- When the “Write EEPROM Succeeded.” screen appears, click the “OK”  button (Figure 6-44 a).

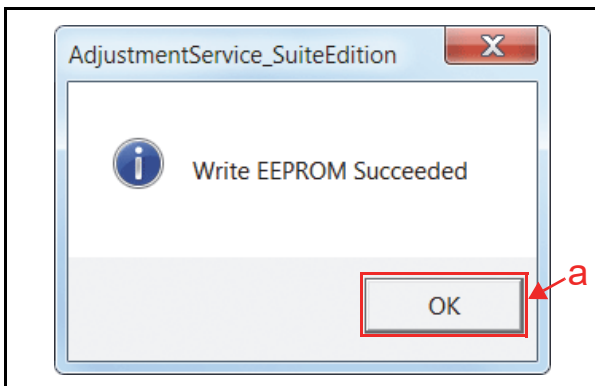



Figure 6-44 Write EEPROM Succeeded

- Click the Close  button (Figure 6-43 b) to shut down the Calibration application. This completes the Sensor Calibration procedures.

Performance Tests

This section provides Performance Testing instructions for the DBV-400 Unit. This section contains the following information:

- Performance Test using a PC
- Performance Test without a PC

Choose one (1) of the two (2) above Performance Test Procedures by selecting the one related to the particular circumstance desired.

Performance Test Using a PC

Refer to “Tool Requirement” on page 6-1 for the Tools and Equipment interconnects necessary to perform a DBV-400 Performance Test using a PC. Table 6-1 lists the test items for the DBV-400 Performance Test using a PC.

Table 6-1 Performance Test Items Using a PC and Test Menu Selections

Test Item	Test Menu Selection (On PC Screen)	Test Purpose
Feed Motor Normal Rotation	FEED_MOTOR_FWD_TEST	Speed Check while Normal Rotation
Feed Motor Reverse Rotation	FEED_MOTOR_REV_TEST	Speed Check while Reverse Rotation
Stacking	STACK_TEST	Stacking Mechanism Movement Check at 3 seconds interval
Sensor Test	SENSOR_TEST	Each Sensor Performance Check
DIP Switch 1 Test	DIPSWITCH1_TEST	DIP Switch 1 Performance Check
DIP Switch 2 Test	DIPSWITCH2_TEST	DIP Switch 2 Performance Check
Bezel LED Test	LED_TEST	Bezel LED Performance Check

Performance Test Preparation

Perform the following steps to prepare the DBV-400 for the Performance Test Procedures:

1. Remove electrical power from the DBV-400 Unit.
2. Set DS1 #8 to ON (Figure 6-45).

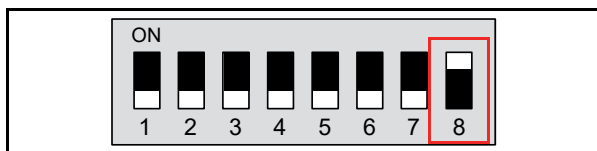

Figure 6-45 DS1 Switch Settings 1

3. Apply electrical power to the DBV-400 Unit. The Bezel LED will flash at a Green color rate when the DBV-400 Unit is in the Performance Test Stand-By Mode.
4. Connect the PC and the DBV-400 Unit together using the recommended USB Cable.
5. Launch the “JCM Tool Suite Standard Edition” Application. The “JCM Tool Suite Standard Edition” Screen shown in Figure 6-46 will appear when the application becomes active.
6. Click the “Service Mode” Pull-down Menu, and select “Performance Test” (Figure 6-46 a).

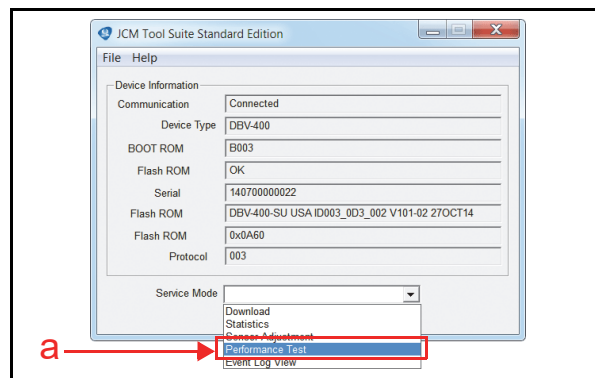

Figure 6-46 JCM Tool Suite Standard Edition Screen/Pull-Down Menu 2

7. Performance Test will appear at the top of the Main Screen (Figure 6-47).

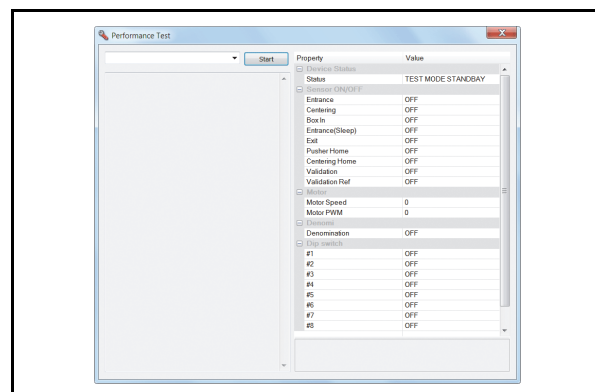

Figure 6-47 Main Screen

Feed Motor Test

Perform the following steps to begin the Feed Motor Test:

1. Launch the Main Screen (refer to “Performance Test Preparation” on page 6-11).
2. Click the “Performance Test” Pull-down Menu, and select the desired performance test item from the available selections (Figure 6-48 a) (refer to “Performance Test Items Using a PC and Test Menu Selections” on page 6-11 for a test item to select).

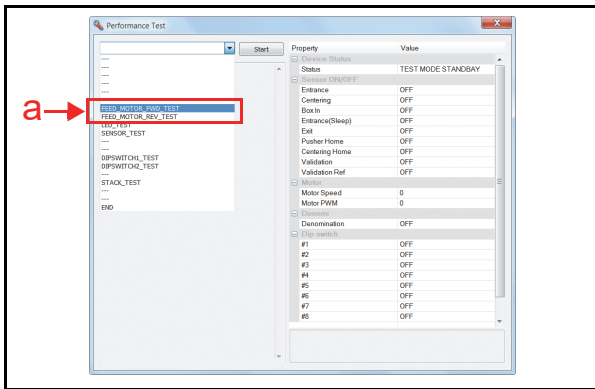

Figure 6-48 Feed Motor Test Selections

3. Click the “Start” Screen Button (Figure 6-49 a) to begin the test.

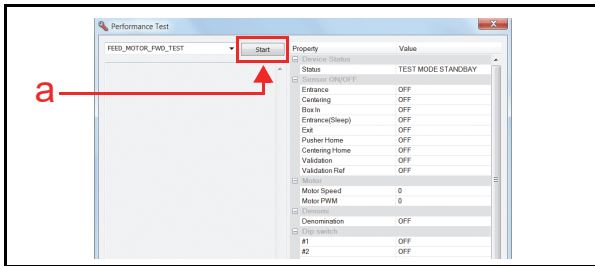

Figure 6-49 Feed Motor Test Screen 1

4. Confirm that the Feed Motor rotates in the proper direction and at an acceptable rate of speed (within approximately 600mm/s to 800mm/s). The measured speed will appear in the “Motor” area (Figure 6-50 b).
5. Click the “Stop” Screen Button (Figure 6-50 a) to end the test.

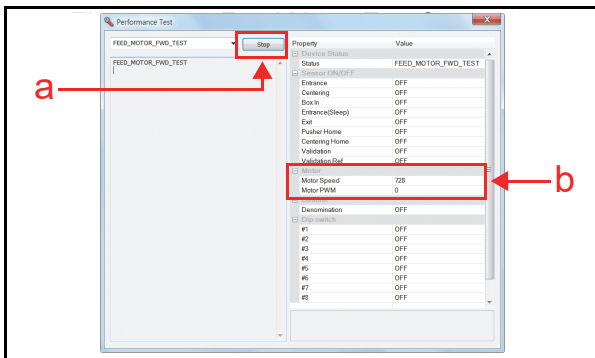

Figure 6-50 Feed Motor Test Screen 2

Stacking Test

Perform the following steps to begin the Stacking Test:

1. Launch the Main Screen (refer to “Performance Test Preparation” on page 6-11).
2. Click the “Performance Test” Pull-down Menu (Figure 6-51 a), and select “STACK_TEST”.

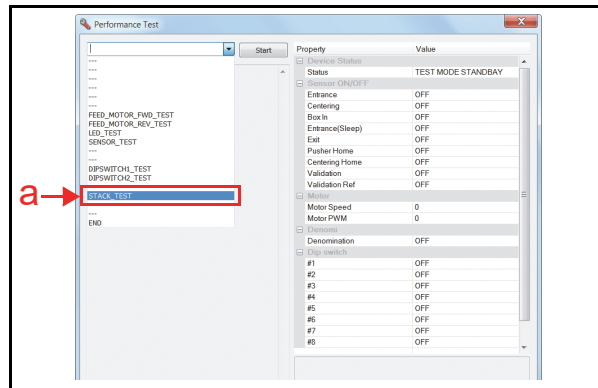

Figure 6-51 Stacking Test Selections

3. Click the “Start” Screen Button (Figure 6-52 a) to begin the test.

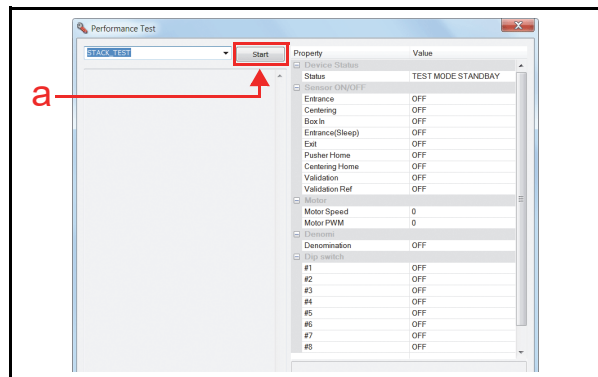

Figure 6-52 Stacking Test Screen 1

4. Confirm that the Stacker mechanism movement is performing a normal rotation.
5. Click the “Stop” Screen Button (Figure 6-53 a) to end the test.

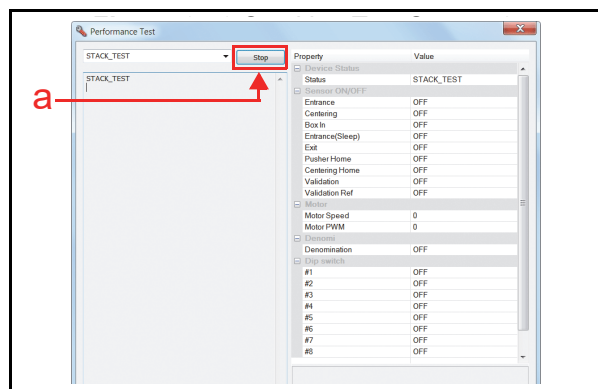

Figure 6-53 Stacking Test Screen 2

Sensor Test

Five (5) Tests exist within the Sensor Test Menu. Table 6-2 lists each Sensor Test Item function.

Table 6-2 Sensor Test Items

Sensor Names *	Test Purpose	Test Procedure	PC Screen	
			Detected	NOT Detected
Entrance Sensor	Detects that a Banknote is present at the Entrance Sensor.	Cover/uncover the Entrance Sensor using a Banknote.	ON	OFF
Box In Sensor	The Box In Sensor detects the presence of a Cash Box.	Push down/release the Cash Box DT Lever.	ON	OFF
Exit Sensor	Detects that a Banknote is present at the Exit Sensor.	Cover/uncover the Exit Sensor using a Banknote.	ON	OFF
Pusher Home Sensor	Detects that the Pusher Mechanism is at the Home Position.	Remove the CPU Circuit Board and block/unblock the Pusher Home Sensor.†	ON	OFF
Validation Sensor (Inside and Outside)	The Outside Sensor detects the presence of a Banknote.	Cover/uncover the Inside and/or Outside Validation Sensor using a Banknote.	ON	OFF

*. Refer to "DBV-400 Component Names" on page 1-5 and "Sensor and Roller Locations" on page 2-12 for component and sensor locations respectively.

†. This test is only available with the CPU Circuit Board removed from the Main Frame Assy. Refer to "CPU Circuit Board Removal" on page 4-1 for the CPU Circuit Board removal.

To perform the Sensor Test, proceed as follows:

1. Launch the Main Screen (Refer to "Performance Test Preparation" on page 6-11).
2. Click the "Performance Test" Pull-down Menu (Figure 6-54 a), and select "SENSOR_TEST".

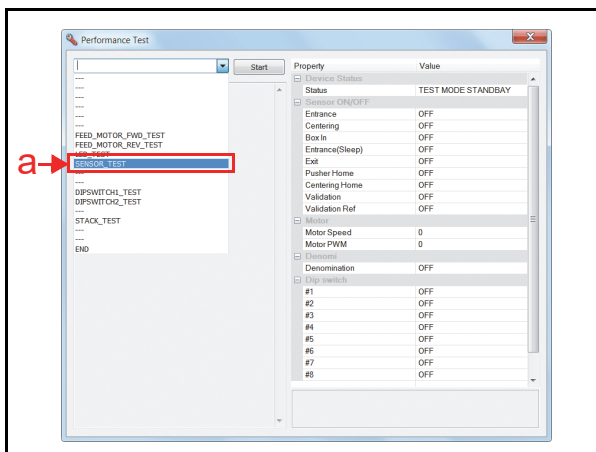

Figure 6-54 Sensor Test Selections

3. Click the "Start" Screen Button (Figure 6-55 a) to begin the test.

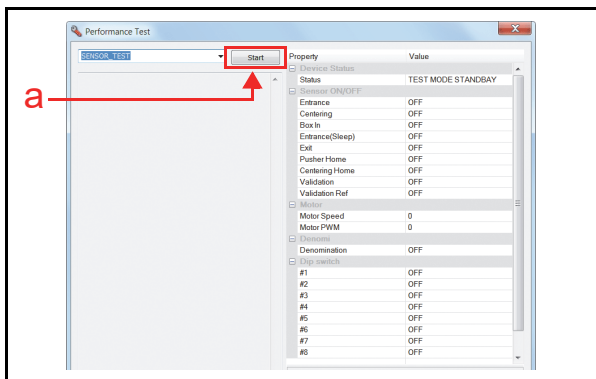

Figure 6-55 Sensor Test Screen 1

4. Perform each Sensor Test (refer to "Test Procedure" in Table 6-2). The resulting condition will appear in the "Sensor ON/OFF" and "Stacker" areas (Figure 6-56 b).
5. Confirm that the resulting condition matches the action stated in Table 6-2.
6. Click the "Stop" Screen Button (Figure 6-56 a) to end the test.

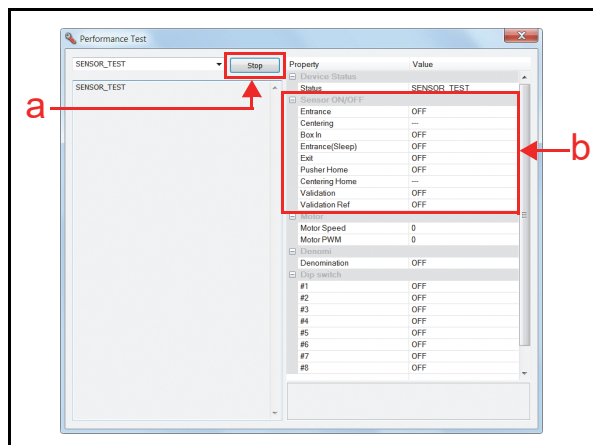

Figure 6-56 Sensor Test Screen 2

DIP Switch Test

Perform the following steps to begin the DIP Switch Test:

1. Launch the Main Screen (refer to “Performance Test Preparation” on page 6-11).
2. Click the “Performance Test” Pull-down Menu (Figure 6-57 a), and select a desired performance test item. (Refer to “Performance Test Items Using a PC and Test Menu Selections” on page 6-11 for a test item to select.)

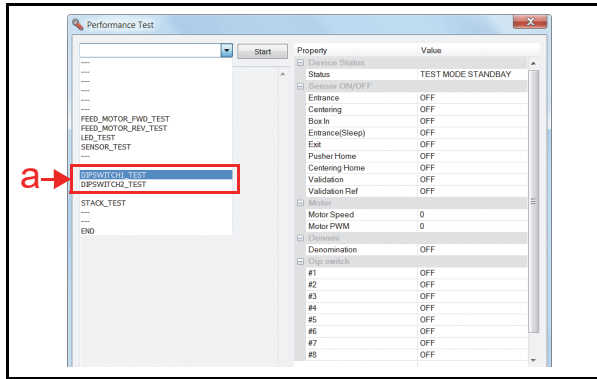

Figure 6-57 DIP Switch Block Test Selections

3. Click the “Start” Screen Button (Figure 6-58 a) to begin the test.

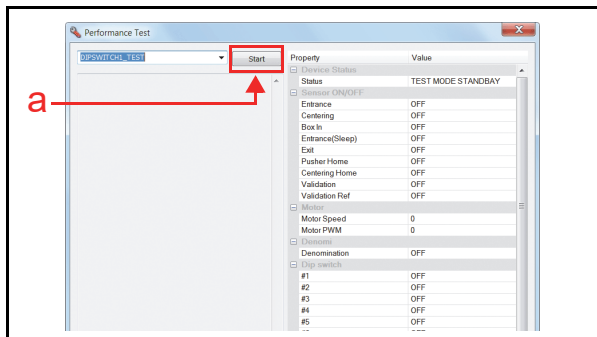

Figure 6-58 DIP Switch Block Test Screen 1

4. Set each DIP Switch to ON and OFF.
5. Confirm that the DIP Switches are performing normally. The Sensor detection condition indicates “ON” or “OFF” in the DIP Switch Box area on the PC.
6. Click the “Stop” Screen Button (Figure 6-59 a) to end the test.

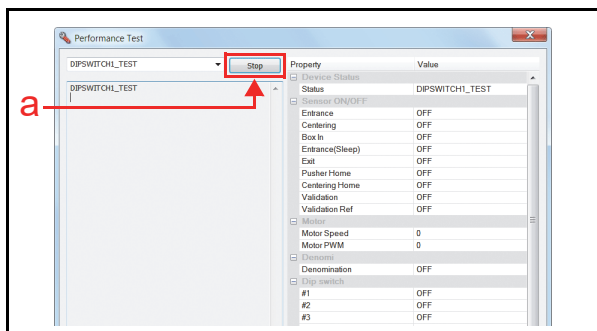

Figure 6-59 DIP Switch Block Test Screen 2

Bezel LED Test

Perform the following steps to begin the LED Test:

1. Launch the Main Screen (refer to “Performance Test Preparation” on page 6-11).
2. Click the “Performance Test” Pull-down Menu (Figure 6-60 a), and select “LED_TEST”.

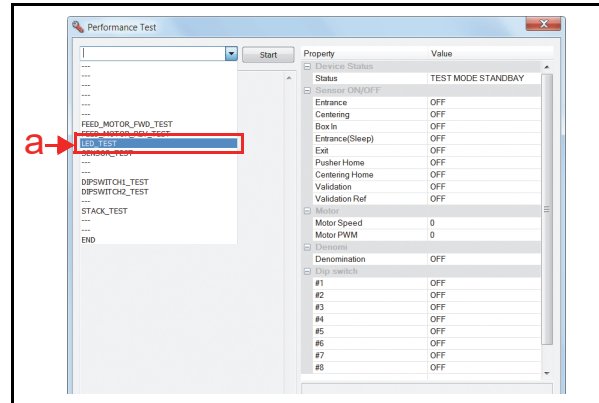

Figure 6-60 LED Test Selections

3. Click the “Start” Screen Button (Figure 6-61 a) to begin the test.

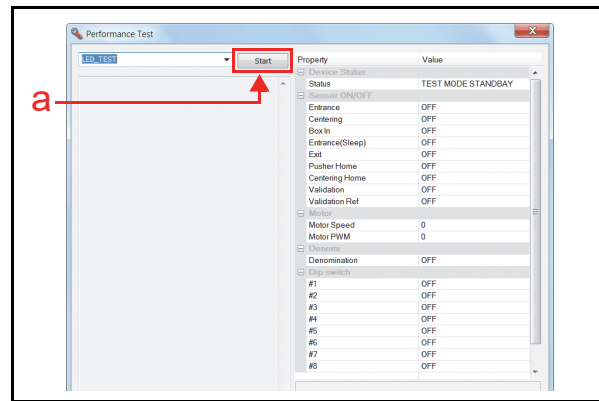

Figure 6-61 LED Test Screen 1

4. Confirm that the Bezel LED cycles between the primary colors (Red, Green, Blue, Yellow, Magenta, Cyan, White, and Extinguished). The LED flash sequence repeats.
5. Click the “Stop” Screen Button (Figure 6-62 a) to end the test.

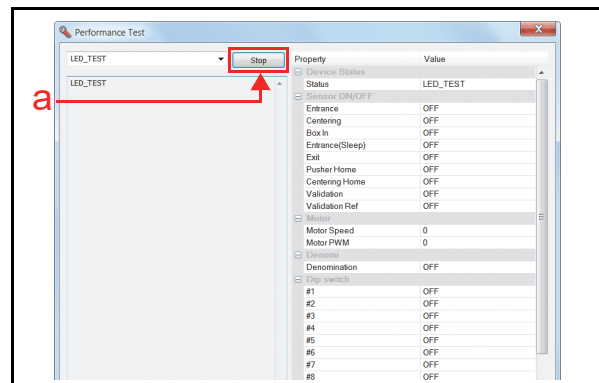

Figure 6-62 LED Test Screen 2

Performance Test Without a PC

See “Without a PC” on page 6-1 for the Tools and Equipment interconnects necessary to perform a DBV-400 performance Test without a PC.

Table 6-3 lists the items and DIP Switch 1 (DIP SW1) settings for the DBV-400 Performance Test.

Table 6-3 Performance Test Items and DIP Switch 1 Settings

Test Item	DIP Switch 1 Setting								Test Purpose *
	1	2	3	4	5	6	7	8†	
Feed Motor Normal Rotation	ON							ON/OFF	Speed Check while Normal Rotation
Feed Motor Reverse Rotation		ON						ON/OFF	Speed Check while Reverse Rotation
Stacking			ON					ON/OFF	Stacking Mechanism Movement Check at 3 seconds intervals
Aging Test‡				ON				ON/OFF	Aging Movement Check at intervals set by DIP SW1 #6 & #7
Sensor Test							ON	ON/OFF	Each Sensor Performance Check
Acceptance Test†	ON	ON	ON	ON				ON/OFF	Acceptance Check with Validation
Acceptance Test†	ON	ON	ON	ON		ON		ON/OFF	Acceptance Check without Validation
Reject Test†	ON	ON	ON	ON	ON		ON	ON/OFF	Reject Check without Validation
DIP Switch 1 Test	ON	ON	ON	ON	ON	ON	ON	ON/OFF	DIP Switch 1 (SW1) Performance
DIP Switch 2 Test		ON	ON	ON	ON	ON	ON	ON/OFF	DIP Switch 2 (SW2) Performance
Bezel LED Test				ON	ON	ON	ON	ON/OFF	Bezel LED Performance Check
Push Button Test	-	-	-	-	-	-	-	-	Push Button Performance Check

*. If any errors occur, refer to Table A-4 “LED Flash Error Codes” on page A-3.

†. DIP SW1 #8 Setting; ON to standby or stop test, OFF to start test.

‡. This test is available when the Cash Box is correctly in place.

Aging Test

To perform the Aging Test, proceed as follows:

1. Remove electrical power from the DBV-400 Unit.
2. Set the DBV-400 DIP SW1 #4 and #8 to ON (Figure 6-63) and the all DIP SW2 switches to OFF (Figure 6-64).



Figure 6-63 Aging Test DIP SW1 Setting

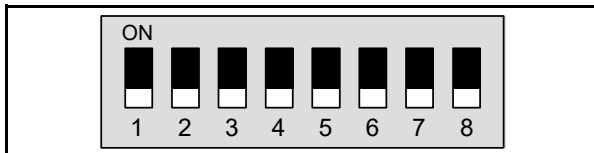

Figure 6-64 Aging Test DIP SW2 Setting

3. Connect the Power Harness and apply electrical power to the DBV-400 Unit.
4. To start the Aging Test, set the DBV-400 DIP SW1 #8 to OFF (Figure 6-65).

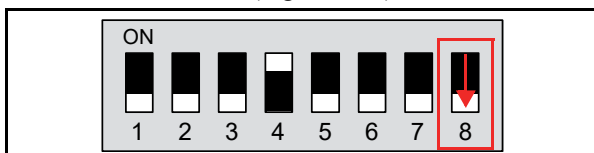

Figure 6-65 DIP SW1 #8 OFF

5. DIP SW1 #6 and #7 can be used to change interval timing of the Aging Test. (See Table 6-4 Aging Test Interval Timing Settings for Switch #6 and #7 settings for each interval.)

Table 6-4 Aging Test Interval Timing Settings

DIP Switch 1		Interval
#6	#7	
OFF	OFF	30 seconds
ON	OFF	1 second
OFF	ON	2 seconds
ON	ON	10 seconds

6. Place the Cash Box onto the DBV-400 Unit to begin the aging movement.
 7. Remove the Cash Box and set the DIP SW1 #8 to ON to end the Aging Test.
- This completes the Aging Test.

Acceptance Test

To perform the Acceptance Test, proceed as follows:

1. Remove electrical power from the DBV-400 Unit.
2. Select the desired Acceptance Test by setting the DIP Switches as indicated in Table 6-3.
3. Set the all DIP SW2 switches to OFF (Figure 6-66)

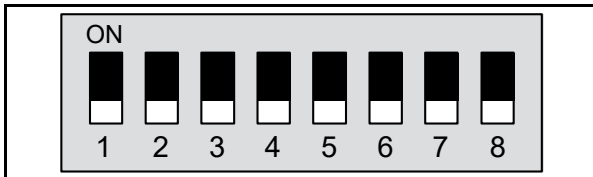

Figure 6-66 Acceptance Test DIP SW2 Setting

4. Apply electrical power to the DBV-400 Unit and confirm that the Bezel LED flashes at a Green color rate.
5. Set the DBV-400 DIP SW1 #8 to OFF (Figure 6-67).

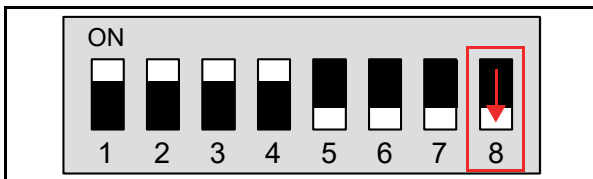

Figure 6-67 DIP SW1 #8 OFF For Acceptance Test With Validation

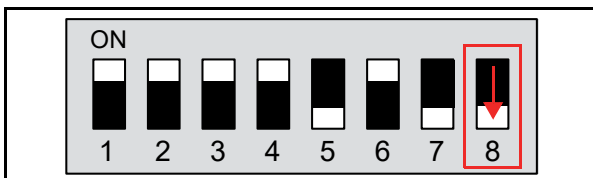

Figure 6-68 DIP SW1 #8 OFF For Acceptance Test Without Validation

6. Place the Cash Box onto the DBV-400 Unit.
7. Confirm that the DBV-400 performs a initialization and goes to idle, waiting for a Banknote insertion. If errors occur, refer to Appendix A Table A-1.
8. Set the DIP SW1 #8 to ON to end the Acceptance Test.

This completes the Acceptance Test.

Sensor Test

To perform the Sensor Test, proceed as follows:

1. Remove electrical power from the DBV-400 Unit.
2. Set the DBV-400 DIP SW1 #7 and #8 to ON (Figure 6-69) and the all DIP SW2 switches to OFF (Figure 6-70).

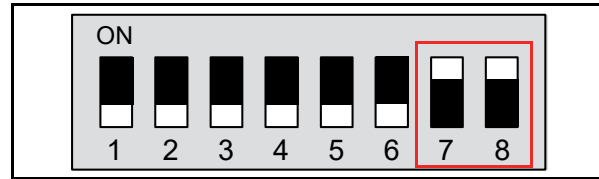

Figure 6-69 Sensor Test DIP SW1 Setting

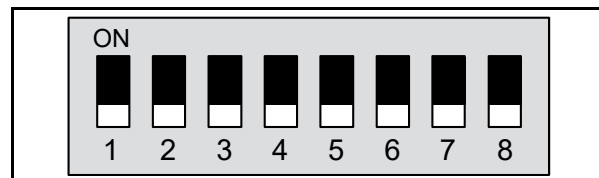

Figure 6-70 Sensor Test DIP SW2 Setting

3. Apply electrical power to the DBV-400 Unit and confirm that the Bezel LED flashes at a Green color rate.
4. Set the DBV-400 DIP SW1 #8 to OFF (Figure 6-71) and confirm that the Bezel LED flashes at a Purple color rate.

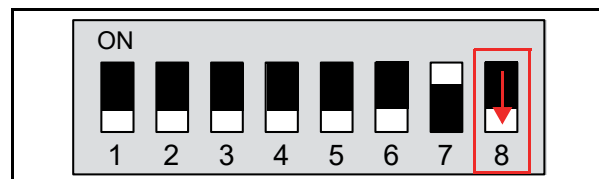

Figure 6-71 DIP SW1 #8 OFF

5. Perform each Sensor Test (refer to “Test Procedure” in Table 6-5).
6. Confirm that the resulting Bezel LED condition matches the Bezel LED color stated in Table 6-5.

Table 6-5 Sensor Test Procedure and Confirmation

Bezel LED Color State		Test Procedure*
Detected	Not Detected	
Red	Extinguished	Cover/uncover the Entrance Sensor using a Banknote.
Blue	Extinguished	Cover/uncover the Validation Sensor using a Banknote.
Yellow	Extinguished	Cover/uncover the Exit Sensor using a Banknote.
White	Extinguished	Push down/release the Cash Box DT Lever.(Box In Sensor).

*. Refer to “DBV-400 Component Names” on page 1-5 and “Sensor and Roller Locations” on page 2-12 for the component and sensor locations respectively.

7. Set the DIP SW1 #8 to ON to end the Sensor Test. This completes the Sensor Test.

Push Button Test

To perform the Bezel LED Test, proceed as follows:

1. Connect the Power Harness and apply electrical power to the DBV-400 Unit.
2. Confirm that the Bezel LED is lit a steady default color.
3. Press the PUSH Button (Figure 6-72 a) in the center until you feel it “click.”

 **NOTE:** Pressing the Push Button too hard may cause damage to the Button. Press the center of the Button slowly and hold it down until “click feeling” can be felt.

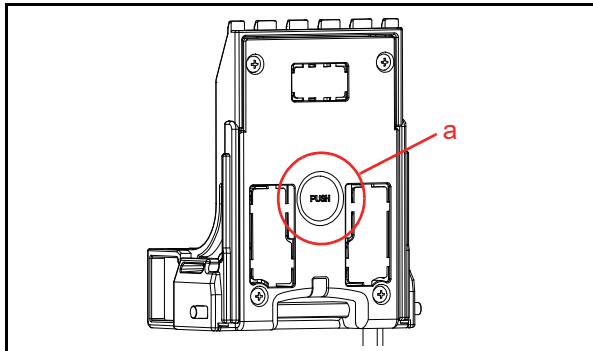

Figure 6-72 Push Button Location

4. Confirm that Bezel LED is lit in the sequential order as follows: Green -> Cyan -> Blue -> Magenta -> White-> Gradation.

This completes the Push Button Test.

DIP Switch Test

To perform the DIP Switch 1 (SW1) and/or DIP Switch 2 (SW2) Test, proceed as follows:

1. Remove electrical power from the DBV-400 Unit.
2. Set the DIP SW1 switches for the desired DIP Switch Test as indicated in Table 6-3.
3. Set the all DIP SW2 switches to OFF (Figure 6-73).

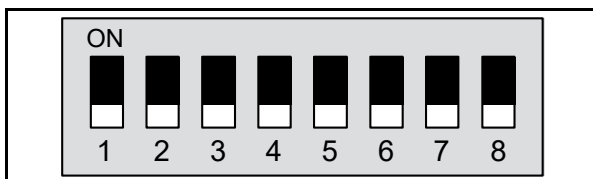

Figure 6-73 DIP Switch Test DIP SW2 Setting

4. Apply electrical power to the DBV-400 Unit and confirm that the Bezel LED flashes at a Green color rate.
5. Set the DBV-400 DIP SW1 #8 to OFF (Figure 6-74 for DS1 Testing or Figure 6-75 for DS2 Testing respectively) and confirm the Bezel LED flashes at a Purple color rate.



Figure 6-74 DIP SW1 #8 OFF for DS1 Testing

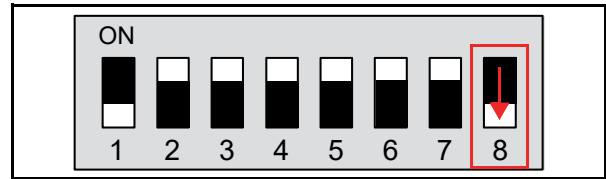

Figure 6-75 DIP SW1 #8 OFF for DS2 Testing

6. Set the switches on DIP SW1 or DIP SW2 ON or OFF as shown in Table 6-6 and Table 6-7.
7. Confirm that the resulting Bezel LED condition matches the color stated in Table 6-6 for DIP Switch 1 Test Confirmation and Table 6-7 for DIP Switch 2 Test Confirmation.

Table 6-6 DIP Switch 1 Test Confirmation

Bezel LED Color*	DIP Switch 1 Setting							
	1	2	3	4	5	6	7	8
White	ON	ON	ON	ON	ON	ON	ON	-
Blue	ON	OFF	ON	OFF	ON	OFF	ON	-
Red	OFF	OFF	OFF	OFF	OFF	OFF	OFF	-

*. The Bezel LED is extinguished when the DIP Switches are set to settings not listed in Table 6-6.

Table 6-7 DIP Switch 2 Test Confirmation

Bezel LED Color*	DIP Switch 2 Setting							
	1	2	3	4	5	6	7	8
White	ON	ON	ON	ON	ON	ON	ON	ON
Blue	ON	OFF	ON	OFF	ON	OFF	ON	OFF
Red	OFF	OFF	OFF	OFF	OFF	OFF	OFF	OFF

*. The Bezel LED is extinguished when the DIP Switches are set to settings not listed in Table 6-7.

8. Set the DIP SW1 #8 to ON to end the DIP Switch Test.

This completes the DIP Switch Test.

Other Performance Tests

To perform the other Performance Tests, proceed as follows:

1. Remove electrical power from the DBV-400 Unit.
2. Select the desired Performance Test by setting the DIP Switches as indicated in Table 6-3.
3. Set the DBV-400 DIP SW1 #8 to ON and the DIP SW2 all switches to OFF (Figure 6-76).

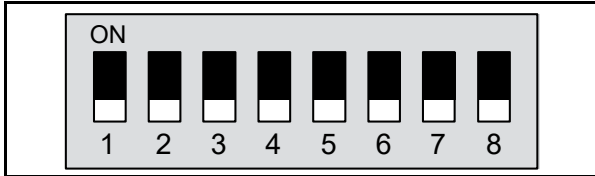

Figure 6-76 Other Tests DIP SW2 Setting

4. Connect the Power Harness and apply electrical power to the DBV-400 Unit.
5. Set the DIP SW1 #8 to OFF to start the test.
6. Confirm that each test is performed normally as stated in Table 6-8.
7. Set the DIP SW1 #8 to ON to end the test.

Table 6-8 Performance Confirmation

Test Item	Performance Confirmation
Feed Motor Normal/Reverse Rotation	Confirm that the Feed Motor rotates normally in a specified direction.
Stacking	Confirm that a cycle movement is performing normally.
Reject Test	Insert a Banknote and then confirm that the Banknote is returned.
Bezel LED	Confirm that the Bezel LED is lit in the order as follows: Red ->Green -> Blue -> Yellow -> Magenta -> Cyan -> White -> Extinguished.

DBV™ Series

DBV-400 Banknote Validator

Section 7

7 EXPLODED VIEWS AND PARTS LISTS

This section provides product exploded views and parts lists for the DBV™ Series DBV-400 Banknote Validator Unit, and contains the following information:



NOTE: Parts may be changed for improvement without notice.

- Entire DBV-400 Unit Exploded View
- DBV-400 Main Unit Exploded View
- DBV-400 Validation Guide Cover Assy. Exploded View
- DBV-400 Validation Guide Exploded View
- DBV-400 Cash Box Exploded View
- DBV-400 Bezel Unit Exploded View

Entire DBV-400 Unit Exploded View

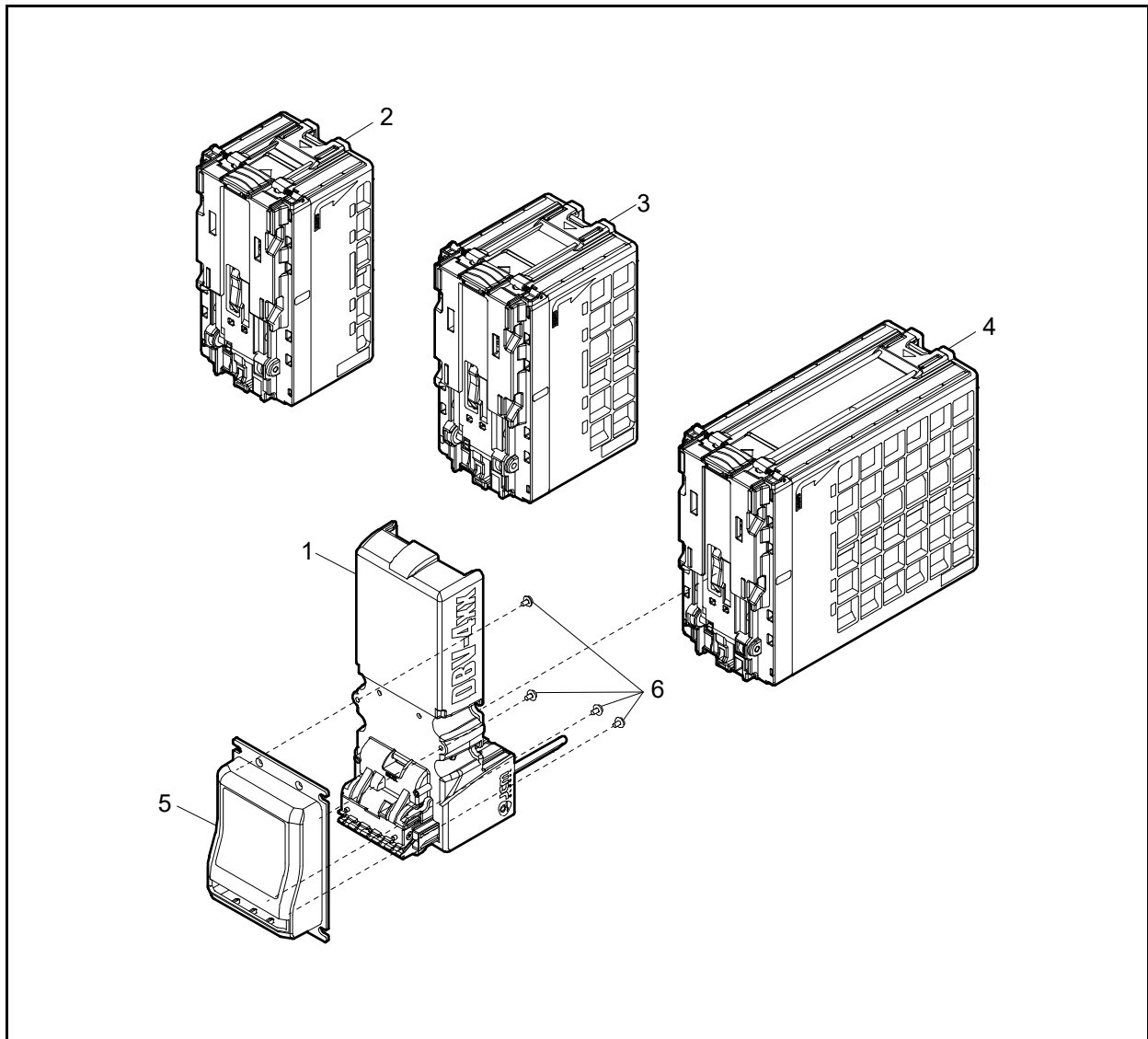

Figure 7-1 Entire DBV-400 Unit Exploded View

Entire DBV-400 Unit**Table 7-1** Entire DBV-400 Unit Parts List

Ref No.	EDP No.	Description	QTY	Remark
1	234375	DBV-400 Main Unit Packing	1	
2	237911	DBV-400 Cash Box Small	1	
	242208	DBV-400 Cash Box Small Rear-Access	1	
3	237912	DBV-400 Cash Box Medium	1	
	242209	DBV-400 Cash Box Medium Rear-Access	1	
4	237913	DBV-400 Cash Box Large	1	
5	234108	DBV-400 Standard Bezel Unit	1	For Standard Bezel
	234110	DBV-400 Snack Mask Bezel Unit	1	For Snack Mask Bezel
	234111	DBV-400 TOB Bezel Unit	1	For TOB Bezel (option)
	240075	DBV-400 Euro Bezel Unit	1	For Euro Bezel
	240076	DBV-400 Compatible Bezel Unit	1	For Compatible Bezel
	242207	DBV-400 Bezel Snack (Green) Packing	1	For Snack Mask Bezel (Green)
6	003610	M3x6 Pan Head W Washer (Large)	4	
	234101	M3x25 Pan Head W Washer (Large)	4	For Snack Mask Bezel
	004006	M3x25 Pan Head W Washer (Large)	4	For Snack Mask Bezel (Green)
-	118746	3210-05-05C	1	External Interface 1 = Standard Harness

DBV-400 Main Unit Exploded View 1

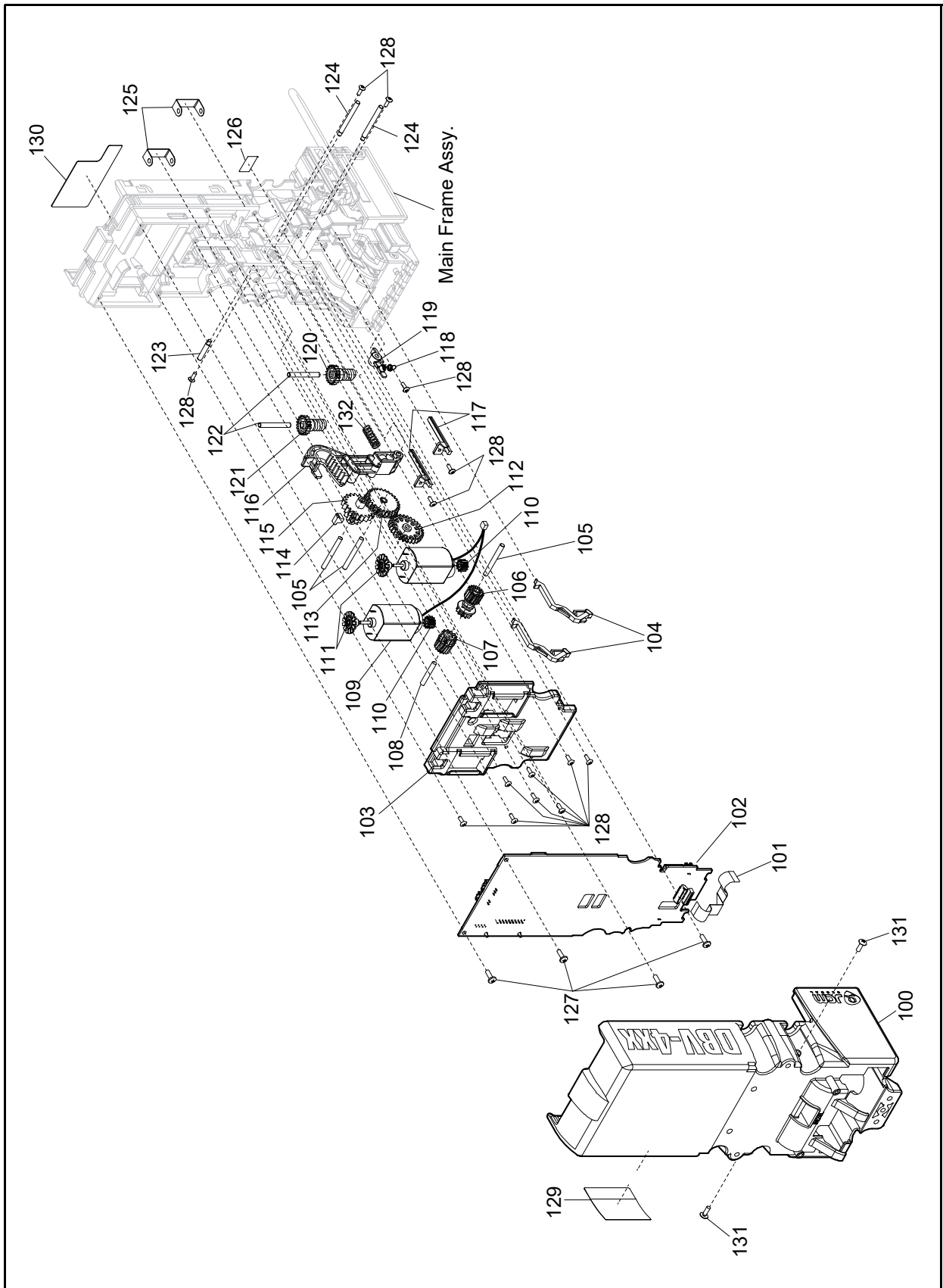

Figure 7-2 DBV-400 Main Unit Exploded View 1

DBV-400 Main Unit Parts List 1**Table 7-2 DBV-400 Main Unit Parts List 1**

Ref No.	EDP No.	Description	QTY	Remark
100	285440	DBV-400 Frame Cover	1	
101	234740	FFC (3520-08-002x)	1	
102	249720	CPU Circuit Board (4107-3520-06-001x-01)	1	
103	242706	Motor Gear Cover D4	1	
104	234050	Entrance Prism D4	2	
105	234092	SUS PIN 3-28	3	
106	231397	Stacker Worm Wheel	1	
107	234022	Transport Worm Wheel	1	
108	234089	SUS PIN 3-20	1	
109	238010	Motor Harness Assy. (3520-08-001x)	1	2 Motors and a Harness are assembled.
110	242995	Motor Pinion Gear	2	A press fit is required for assembly
111	231424	Motor Encoder	2	A press fit is required for assembly
112	234023	Transport Gear 0.8-Z29	1	
113	236948	Stacker Gear A	1	
114	231435	Sound Deadening Block	1	
115	231395	Stacker Gear B	1	
116	236946	Stacker Arm	1	
117	234051	Exit Prism D4	2	
118	234099	B-SW Lever Spring	1	
119	234053	BOX DT LEVER	1	Cash Box DT Lever
120	242622	Stacker Worm Gear	1	
121	239923	Transport Worm Gear	1	
122	234087	SUS PIN 3-25	2	
123	234091	Transport Gear Shaft	1	
124	234090	Stacker Arm Shaft	2	
125	231406	Worm Gear Holder	2	
126	204889	Version Label	1	
127	144840	2.6x8 Phillips, Self-Tapping, Binding Head Screw (Black)*	4	
128	148572	2x6 Phillips, Self-Tapping, Truss Head Screw*	14	
129	238465	Connector Label	1	
130	238464	DIP Switch Label	1	
131	149787	2.6x6 LAMIMATE PS-TITE II (Trox)	2	
132	231378	Stacker Arm Spring	1	

*. P-TITE is recommended.

DBV-400 Main Unit Exploded View 2

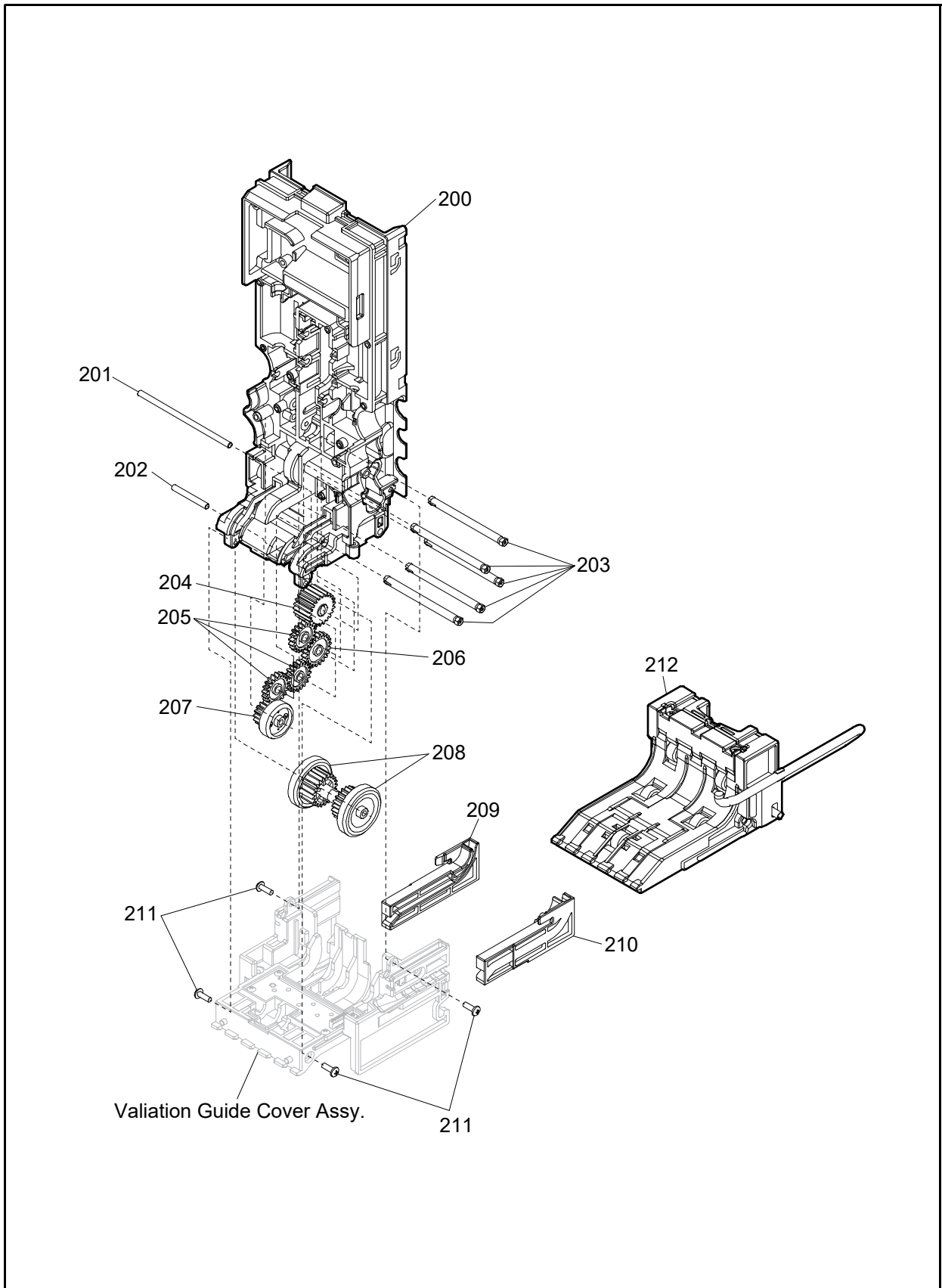

Figure 7-3 DBV-400 Main Unit Exploded View 2

DBV-400 Main Unit Parts List 2**Table 7-3 DBV-400 Main Unit Parts List 2**

Ref No.	EDP No.	Description	QTY	Remark
200	244550	Main Frame	1	
201	234088	SUS PIN 3-66.8	1	
202	234087	SUS PIN 3-25	1	
203	234054	Hex Head P-Shaft	5	
204	234021	Centering Gear 0.8-Z22	1	
205	234020	Gear 0.8-Z20	3	
206	234024	Transport Gear 0.8-Z22	1	
207	239927	Transport Roller Gear A	1	
208	234085	Drive Roller Gear 28-2	2	
209	234057	Guide Chip D4-66A	1	
	234055	Guide Chip D4-72A	1	
210	234058	Guide Chip D4-66B	1	
	234056	Guide Chip D4-72B	1	
211	144840	2.6x8 Phillips, Self-Tapping, Binding Head Screw (Black)*	4	
212	-	DBV-400 Outside Guide Unit	1	Validation Guide

*. P-TITE is recommended.

DBV-400 Validation Guide Cover Assy. Exploded View

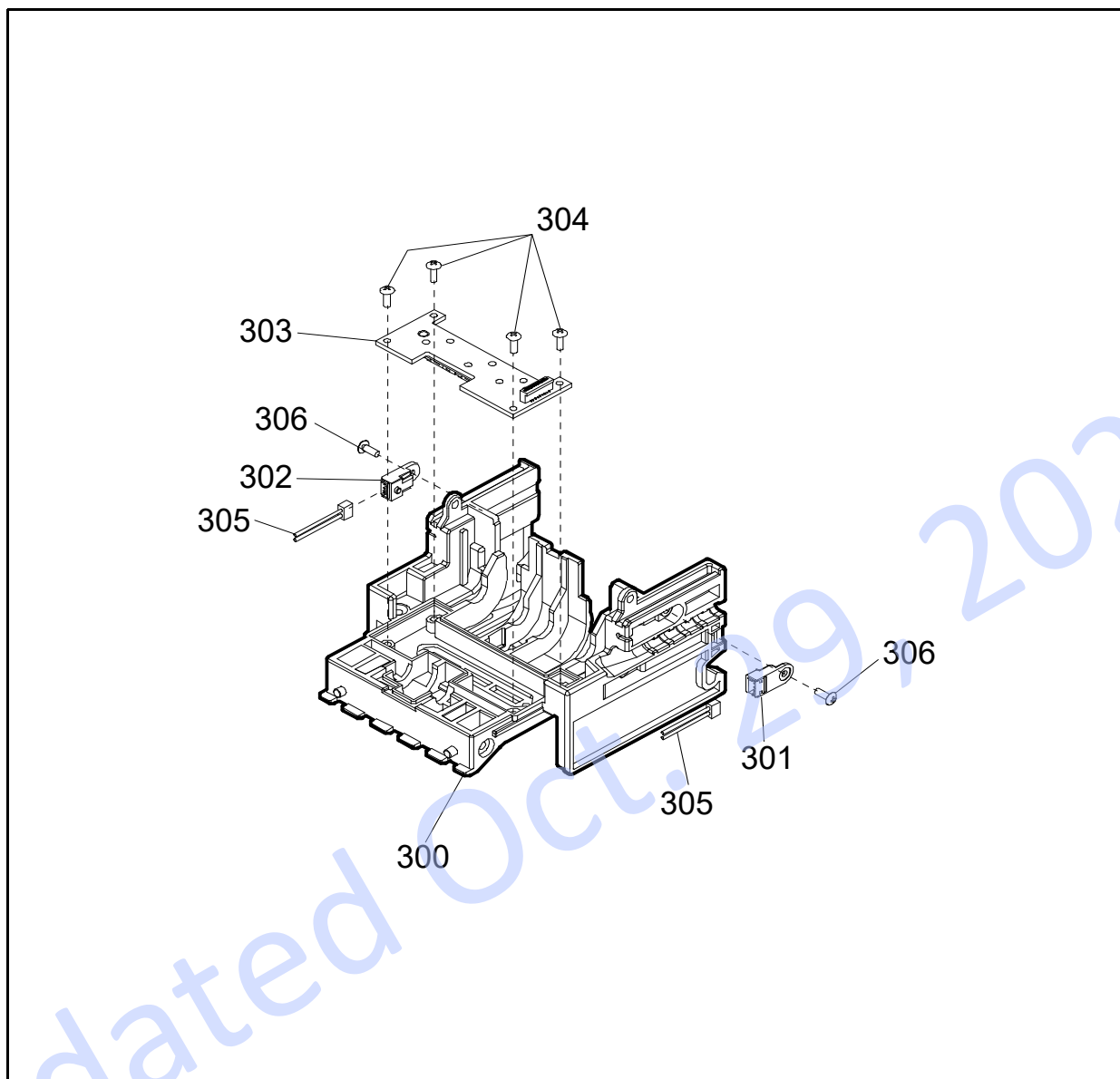

Figure 7-4 DBV-400 Validation Guide Cover Assy. Exploded View

DBV-400 Validation Guide Cover Assy. Parts List

Table 7-4 DBV-400 Validation Guide Cover Assy. Parts List

Ref No.	EDP No.	Description	QTY	Remark
300	244551	Validation Guide Cover D4	1	
301	237715	KB5201-JC22LF Side Sensor	1	
302	237714	KB5201-JC12LF Side Sensor	1	
303	237718	Inside Validation Sensor Board (4107-3520-003x-01x)	1	
304	148572	2x6 Phillips, Self-Tapping, Truss Head Screw*	4	
305	237716	Side Sensor Harness (3520-05-006x)	2	
306	091523	2x5 Self-Tapping, 4.5 H5 LAMIX Screw	2	

*. P-TITE is recommended.

DBV-400 Validation Guide Exploded View

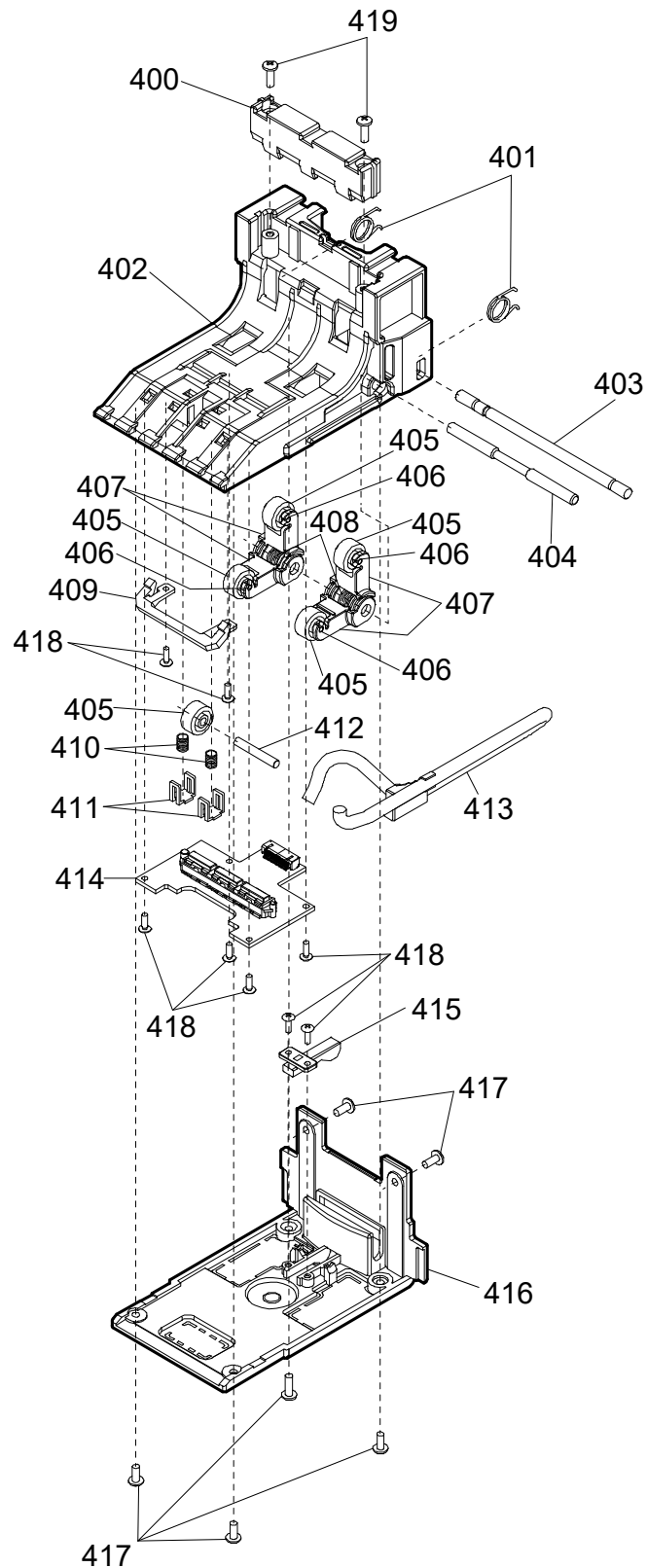

Figure 7-5 DBV-400 Validation Guide Exploded View

DBV-400 Validation Guide Parts List**Table 7-5 DBV-400 Validation Guide Parts List**

Ref No.	EDP No.	Description	QTY	Remark
400	234061	Outside Guide Prism B	1	
401	238466	OG Latch Spring	2	
402	238467	B-Guide Outside	1	
403	238490	Latch Shaft	1	
404	234094	Roller Arm Shaft	1	
405	238468	Driven Roller	5	
406	234095	Roller Pin	4	
407	234062	Roller Arm D4	4	
408	234025	Roller Arm Spring	2	
409	234064	Outside Guide Prism A	1	
410	234015	F-Roller Spring D4	2	
411	102977	Spring Stopper	2	
412	234089	SUS PIN 3-20	1	
413	244005	Outside Validation Sensor Cable	1	
414	244004	Outside Validation Sensor Board	1	
415	238204	Blinker LOD	1	
416	245688	Outside Guide Cover	1	
417	104010	2.6x6 Phillips, Self-Tapping, Binding Head Screw *	6	
418	148572	2x6 Phillips, Self-Tapping, Truss Head Screw *	8	
419	144840	2.6x8 Phillips, Self-Tapping, Binding Head Screw (Black) *	2	

*. P-TITE is recommended.

DBV-400 Cash Box Exploded View

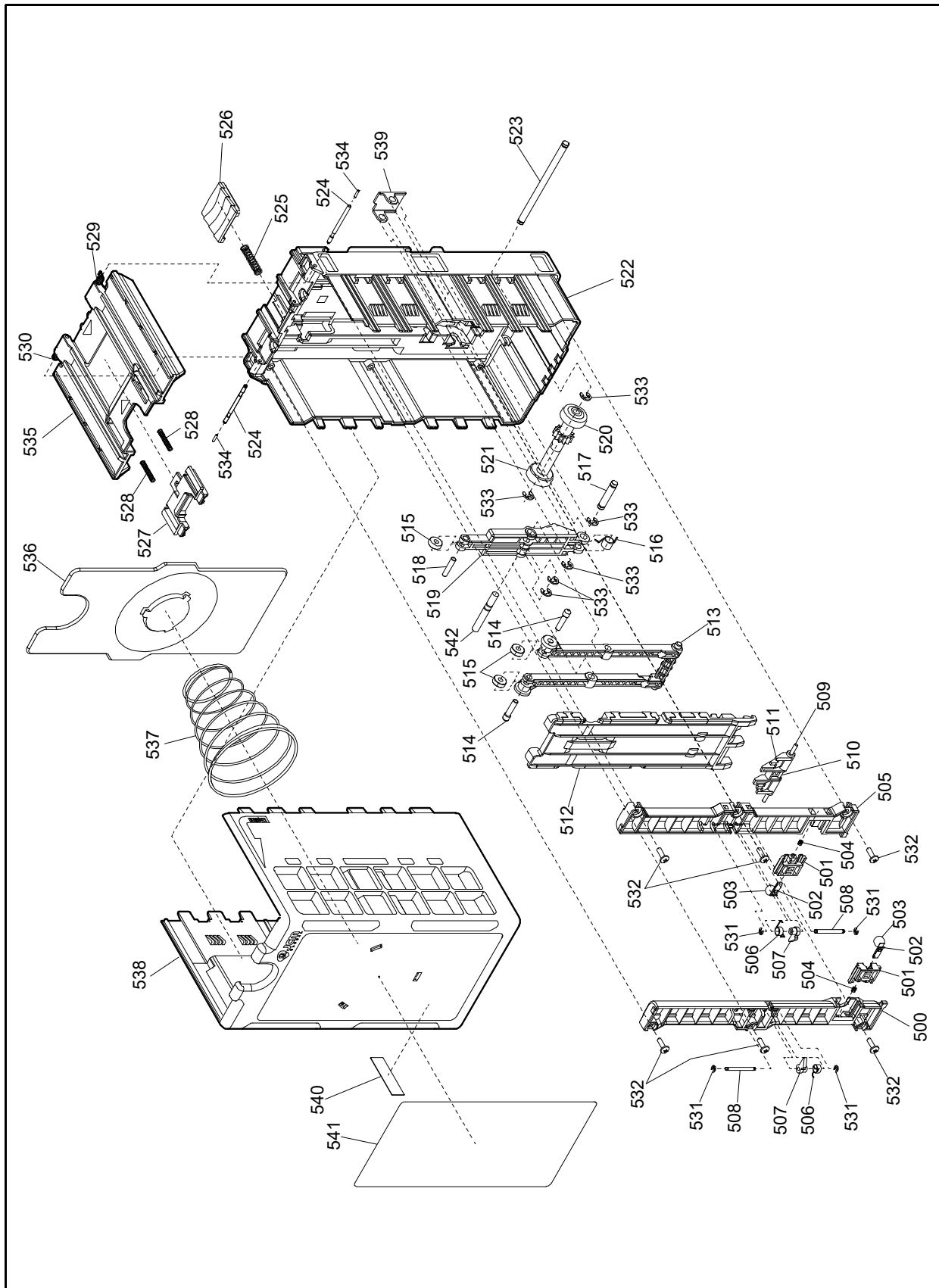

Figure 7-6 DBV-400 Cash Box Exploded View

DBV-400 Cash Box Parts List

Table 7-6 DBV-400 Cash Box Parts List

Ref No.	EDP No.	Description	QTY	Remark
500	290810	Box B-Guide B-D4	1	
501	239114	Box-B Bracket D4	2	
502	238463	Ball Spring PT D4	2	
503	236966	1/4 Inch High-end PA66 (66 Nylon)	2	
504	231380	Box Ball Spring	2	
505	290809	Box B-Guide A-D4	1	
506	070720	Stacker Lever Spring	2	
507	070742	Stacker Lever Right	2	
508	234098	Pusher Lever Shaft	2	
509	231471	Lever Shaft	1	
510	231399	PB Arm Spring	1	
511	231443	Pusher Lever	1	
512	269566	Pusher Plate	1	
513	231445	Pusher Arm B	1	
514	231475	Pusher Shaft B	2	
515	231461	Pusher Roller	3	
516	257066	Box Arm Spring	1	
517	269568	Pusher Arm Shaft	1	
518	231474	Pusher Shaft A	1	
519	269565	Pusher Arm A	1	
520	244544	Transport Roller Gear D	1	Non-Service Part
521	242658	Transport Roller Gear C	1	Non-Service Part
522	244545	Box Base D4	1	
523	234097	Box Roller Shaft	1	Non-Service Part
524	239498	D4 B-Door Pin	2	
525	234018	Box Latch Spring	1	
	242200	Rear-Access Box Latch Spring	1	For Rear-Access Cash Box
526	244546	Box Latch D4 (blue)	1	
	242203	Rear-Access Box Latch D4 (black)	1	For Rear-Access Cash Box
527	238205	Door Lock D4	1	
528	234019	B-Door Latch Spring	2	
	234027	Box Door Spring S1	1	For DBV-400 Small Cash Box
529	270495	Box Door Spring L1	1	For DBV-400 Medium and Large Cash Box
	234028	Box Door Spring S2	1	For DBV-400 Small Cash Box
530	270496	Box Door Spring L2	1	For DBV-400 Medium and Large Cash Box
531	003704	φ1.5 E-Ring SUS	4	
532	144840	2.6x8 Phillips, Self-Tapping, Binding Head Screw (Black)*	6	
533	003707	φ3 E-Ring SUS	6	

Table 7-6 DBV-400 Cash Box Parts List (Continued)

Ref No.	EDP No.	Description	QTY	Remark
534	239497	Wave Shaped Spring Pin, Light Load	2	
535	234069	Box Door D4-300	1	For DBV-400 Small Cash Box
	244547	Box Door D4-500	1	For DBV-400 Medium Cash Box
	244548	Box Door D4-1K	1	For DBV-400 Large Cash Box
536	238462	Box Receive Plate D4	1	For DBV-400 Small and Medium Cash Box
	234077	Box Receive Plate D4-1K	1	For DBV-400 Large Cash Box
537	238199	Box Spring D4-300	1	For DBV-400 Small Cash Box
	238200	Box Spring D4-500	1	For DBV-400 Medium Cash Box
	231386	Box 1500 Spring	2	For DBV-400 Large Cash Box
538	239112	Box Frame D4-300	1	For DBV-400 Small Cash Box
	239115	Box Frame D4-500	1	For DBV-400 Medium Cash Box
	239116	Box Frame D4-1K	1	For DBV-400 Large Cash Box
539	234043	Pusher Hinge Plate	1	
540	234034	Serial Number Label	1	
541	238461	Instruction Label	1	
542	269569	Center Arm Shaft	1	

*. P-TITE is recommended.

DBV-400 Bezel Unit Exploded View

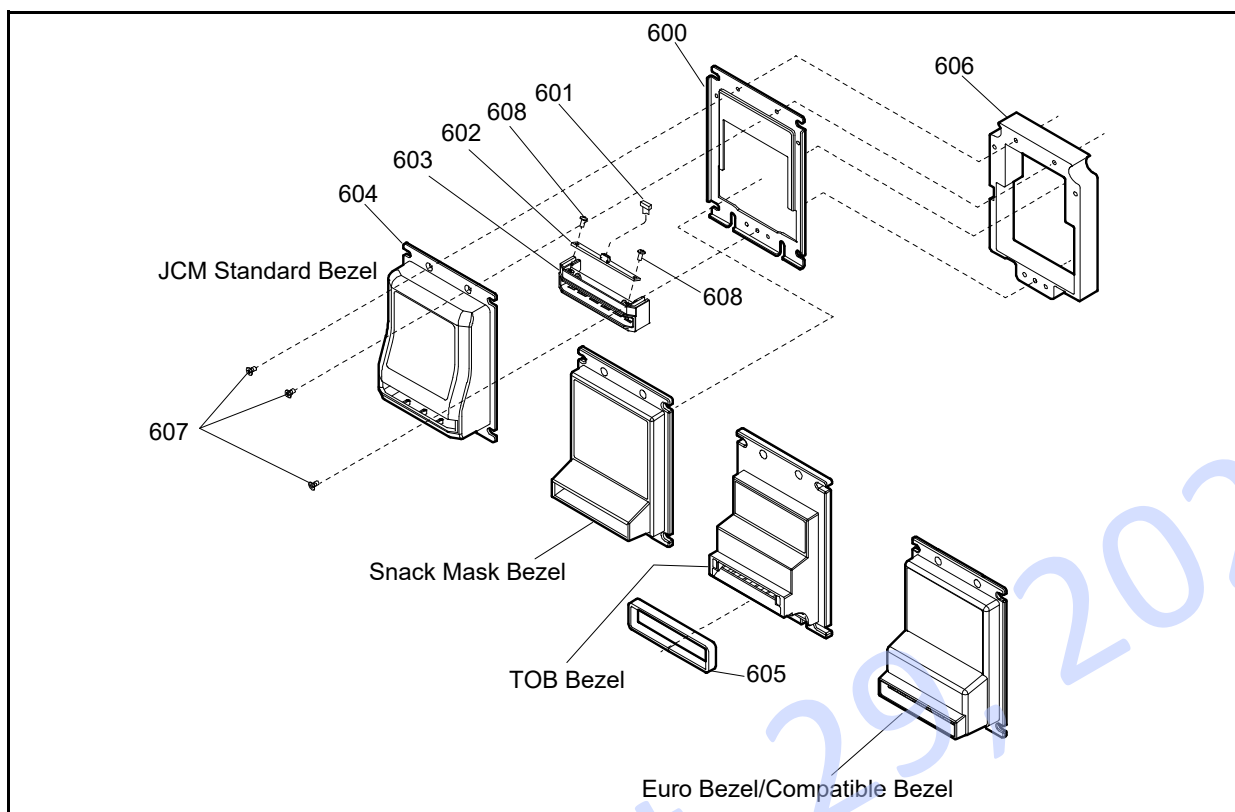

Figure 7-7 DBV-400 Bezel Unit Exploded View

DBV-400 Bezel Unit Parts List

Table 7-7 DBV-400 Bezel Unit Parts List

Ref No.	EDP No.	Description	QTY	Remark
600	238201	DBV-400 Mount Holder	1	
	238202	DBV-400 TOB Mount Hold	1	For TOB Bezel
601	233991	Bezel Harness	1	
602	238054	Bezel Road	1	
603	234079	DBV-400 Standard Bezel Insert	1	For Standard Bezel & Compatible Bezel
	238567	DBV-400 Snack Mask Bezel Insert	1	For Snack Mask Bezel & Snack Mask Bezel (Green)
	238569	DBV-400 TOB Bezel Insert	1	For TOB Bezel & Euro Bezel
604	234078	DBV-400 Standard Bezel	1	For Standard Bezel
	234080	DBV-400 Snack Mask Bezel	1	For Snack Mask Bezel
	238568	DBV-400 TOB Bezel	1	For TOB Bezel
	240073	DBV-400 Euro Bezel	1	For Euro Bezel
	240074	DBV-400 Compatible Bezel	1	For Compatible Bezel
	242205	DBV-400 Bezel Snack (Green)	1	For Snack Mask Bezel (Green)
605	234035	Bezel Sponge	1	TOB Bezel Only
606	120985	Window Spacer	1	For Snack Mask Bezel & Snack Mask Bezel (Green)
607	062448	M3x6 Flat Head (F-Loc)	3	
608	104010	2.6x6 Phillips, Self-Tapping, Binding Head Screw*	2	

*. P-TITE is recommended.

THIS PAGE INTENTIONALLY LEFT BLANK

DBV™ Series

DBV-400 Banknote Validator

Section 8

8 INDEX

C

Calibration

Methods of... 6-5

Cleaning

methods of, and equipment required for... 2-11, 2-12

Communications

criteria regarding receipt of... 3-1

Contact Information

Address and Telephone Numbers for... 1-11

D

DBV-400

photo of a... 1-1

Dimensions

entire unit clearance

illustrated drawing for... 1-8

F

Fault Table

table listings of... A-1

Flowchart

Operational... 2-21

I

Installation

steps required for... 2-1

M

Model Descriptions

Product Number Specifications of... 1-2

N

Navigation

within manual

procedure for... 1-1

P

PC Calibration

Preparation for... 6-8

Performance Testing

instructions for... 6-1, 6-11

Pin Assignments

Table Listing of... 2-3

Precautionary Symbols

types of... 1-2

Primary Features

DBV-400

DBV Product Series of... 1-4

S

Safety

pictographs indicating

1 to 3 symbols inside boxed area... 1-1

Software Descriptions

Product Number Specifications of... 1-2

Steps

sequential numbering of... 1-1

T

Tool Requirements

workbench... 4-1

Troubleshooting

Instructions for... A-1

Type Descriptions

Product Number Specifications of... 1-2

W

Wiring Diagram

system & individual primary part... 5-1

THIS PAGE INTENTIONALLY LEFT BLANK

DBV™ Series

DBV-400 Banknote Validator

Appendix A

A TROUBLESHOOTING

This section provides troubleshooting instructions for the DBV™ Series DBV-400 Banknote Validator Unit, including the following information:

- Introduction
- Troubleshooting Overview
- Fault Table Listings
- LED Indication Conditions
- Maintenance Equipment

Introduction

Most Banknote Validator failures result from minor causes. Before replacing any parts, be sure that all assembly and circuit board connectors are properly fitted with their harnesses properly connected.

Poor performance by the DBV-400 Banknote Validator is often caused when dust or foreign objects adhere to the sensors or rollers. Clean the Banknote validation section first, then carefully observe the operating state of the Validator when re-initializing power. This observation is important in locating any causes of failure and the possible fault location.

Perform all repairs by referring to Calibration and Testing in Section 6 of this Manual, and the Disassembly/Reassembly instructions in Section 4 of this Manual.

Troubleshooting Overview

This product allows the operator to perform fault diagnosis by checking various Fault Table Listings against the symptoms. Survey the cause(s) of any failure occurrences during the process.

After determining the cause of the failure, execute the Performance Test, and then repair the unit, replacing any appropriate parts deemed necessary.

Fault Table Listings

Table A-1, Table A-2 and Table A-3 list the various possible DBV-400 Unit fault conditions that can occur and the necessary actions required to correct them.

Table A-1 General Fault Conditions

Symptoms/Error Messages	Possible Fault Causes	Corrective Action Required
Banknote Validator is not working (does not accept any Banknotes)	No external Power is applied to the Banknote Validator (+12 - 24V DC & GND).	Verify that the Power Supply +12 -24V DC and Ground Cables are connected to their appropriate Pins on the main connector.
	Wrong or inappropriate connections	Verify that all Harness Connectors are properly seated. Check for any bent, missing or damaged Pins in the Connector Plugs and mating Receptacles.
	Corrupted Software	Re-download the correct Software.
	CPU Board failure	Conduct an Initial Operational Test. If the test result is Negative (NG), replace the CPU Board. Make sure to re-calibrate the Sensors after the CPU Board is replaced.
Banknote jams occur often	A Pressure Roller is dirty or damaged.	Clean all Pressure Rollers. Replace as necessary.
	A Pressure Roller Spring is loose or missing.	Check all Pressure Roller Springs using a finger pressure test. Replace as necessary.
	A foreign object is lodged in the Transport Path and/or inside the Cash Box.	Clean the Transport Path and remove any foreign object discovered.
	The Validation Guide is not properly seated all the way into the DBV-400 Unit.	Reseat the Validation Guide into the DBV-400 Unit so it is firmly seated all the way into the Frame. Ensure the Validation Guide Release Lever (Open/Close Latches - refer to Figure 1-4 n) are securely locked onto the Frame.
	Banknote is wider than 72 mm or narrower than 60mm	Use only Banknotes widths having the correct DBV-400 Unit's size specifications.

Table A-1 General Fault Conditions (Continued)

Symptoms/Error Messages	Possible Fault Causes	Corrective Action Required
Acceptance rates	Dirt and/or stains on the Rollers and Lenses	Clean the Transport Path. Refer to the "Cleaning Procedure" on page 2-11.
	The Unit has been disassembled, and calibration adjustments have not occurred following a reassembly.	Calibrate the Sensors after reassembling the DBV-400 Unit.
	The wrong Software version or an older Software version is being used.	Make sure that the programmed Software is the latest version, and it supports the Currency values for the specific Country (e.g., check denomination/issuing year).
	Software not designed to accept current Banknotes	Check the particular specifications for the required Banknote Type Acceptance, and make sure the Banknotes will be accepted by the Software loaded (e.g., check denomination/issuing year).
All Banknotes being rejected	Incorrect software (different Currency type)	Download the correct Software for the Currency being accepted.
	Banknotes are not being accepted by the Software.	Make sure the Banknote values required are included in the Software Specifications (e.g., denominations/issuing year).
	Incorrect DIP Switch settings	Enable all denominations by setting all DIP Switches to OFF.
	Banknote acceptance is being inhibited by a Host Controller command.	Enable Banknote acceptance for the required Host Command.
	Validation Sensor failure	Change the CPU Board and Sensor Board and calibrate the Sensors.
Unit was disassembled and calibration did not occur following reassembly	Calibrate all Sensors following reassembly.	
Motor continues to run	A foreign object or a jammed Banknote is stuck in the Transport Path.	Open the Validation Guide (refer to Figure 2-7) or Cash Box Door (refer to Figure 2-3 or Figure 2-4), remove the foreign object or jammed Banknote, and then close the Validation Guide or Cash Box Door.
	Motor Driver failure	Conduct a Forward/Reverse Motor Rotation Test.
Cannot enter the TEST mode	Incorrect DIP Switch settings	Set the DIP Switch DIP SW1 #8 to ON, and reapply power to the DBV-400 Unit.
	DIP Switch failure	Refer to "DIP Switch Test" on page 6-14 regarding the DIP Switch Test, and conduct a DIP Switch TEST to check if the specific DIP Switch Block contains a failure.
	CPU Board failure	Exchange the CPU Circuit Board with a known good Circuit Board and calibrate the Sensors.

Adjustment Error

Table A-2 lists the various possible DBV-400 Unit Adjustment fault conditions.

Table A-2 Adjustment Fault Conditions

Symptoms/Error Messages	Possible Fault Causes	Corrective Action Required
Cannot start the Sensor Adjustment program from JCM Tool Suite	PC Operating System (OS) is not compatible	The current Adjustment program only supports the Windows 2000/XP/Windows 7 Operating Systems.
	The Program Files are corrupted.	Request the correct programs from JCM.
Communication Error	Wrong or inappropriate connections	Check the PC Harness connections and the related DBV-400 Interface Connectors for damage. Check for any bent, missing or damaged Pins in the Connector Plugs and/or Receptacles.
	DBV-400 Switch settings are incorrect.	Reset the DIP Switch DIP SW1 #8 to ON, and reapply power to the DBV-400 Unit.
	DIP Switch failure	Refer to "DIP Switch Test" on page 6-14 regarding DIP Switch settings and conduct a DIP Switch Test.
	CPU Board failure	Exchange the CPU Circuit Board with a known good Circuit Board.
Adjustment Error	Incorrect Reference Paper type	Follow the instructions provided in the "DBV-400 Calibration Tool for Maintenance.exe" Program and use the correct Reference Paper.
	Validation Sensor failure	Change the CPU Board and Sensor Board.

Communication Error

Table A-3 lists the various possible DBV-400 Unit Communication fault conditions.

Table A-3 Communication Fault Conditions

Symptoms/Error Messages	Possible Fault Causes	Corrective Action Required
Cannot communicate with the Host Machine	DIP Switch settings are incorrect.	Set all DIP Switches to OFF, and then set DIP Switches correctly while referring to the "Software Information Sheet."
	Connectors are disconnected or loosely connected.	Firmly re-seat all of the Communication Connectors.
	Damaged Connector Pins	Check for any bent, missing or damaged Pins in the Connector Plugs and mating Receptacles.
	CPU Board is corrupted	Exchange the CPU Circuit Board with a known good Circuit Board.
	Incorrect Interface	Verify that the correct interface between the Host Machine and the Banknote Validator is being used.

LED Indication Conditions

The Bezel LED and Status LED indicate various combinations of solid or alternating Color light flashing conditions when any of the Standard Error and Reject Codes listed in Table A-4 and Table A-5 occur.

Identify the cause and solution for an indicated error by comparing it against each listing in Table A-4 and Table A-5.



NOTE: Error Codes and Reject Codes flash different patterns when in the Normal Operation mode (communicating with the Host Machine) or when running the Performance Tests. The LED shows more detailed flash patterns while running the Performance Tests to identify the specific error causes.

LED Flash Error Code Conditions

Table A-4 lists the various LED Flash Error Code causes and solutions for Banknotes.

Table A-4 LED Flash Error Codes

Normal Operation	Performance Test	Error	Causes and Solutions
Bezel LED Sequence	Bezel LED & Status LED Sequence		
White (3)	White (1)	External Flash ROM Boot Program ROM Check Error	The Boot Program that is supposed to run after Power is supplied is not correctly written in ROM, or it cannot be read. [Solution] Check that the following part is properly assembled and/or Harness are connected. [Relative Parts] CPU Circuit Board. If the error is not resolved, change the above related part or parts and calibrate the DBV-400 Unit.
White (3)	White (2)	External Flash ROM Boot I/F Area ROM Check Error	The Boot Interface Area was not written correctly or cannot be read. [Solution] Re-download the Program. If the error is not resolved, check that the following part is assembled and/or Harness are connected. [Relative Parts] CPU Circuit Board. If the error is not resolved, change the above related part or parts and calibrate the DBV-400 Unit.
		External Flash ROM Main Program ROM Check Error	The Main Operating Program is not written into the ROM correctly, or cannot be read. [Solution] Re-download the Program. If the error is not resolved, check that the following part is properly assembled and/or Harness are connected. [Relative Parts] CPU Circuit Board. If the error is not resolved, change the above related part or parts and calibrate the DBV-400 Unit.
White (3)	White (3)	CPU Internal RAM Check Error	RAM reading or writing was not properly performed. [Solution] Check that the following part is properly assembled and/or Harness are connected. [Relative Parts] CPU Circuit Board. If the error is not resolved, change the above related part or parts and calibrate the DBV-400 Unit.

Table A-4 LED Flash Error Codes (Continued)

Normal Operation	Performance Test	Error	Causes and Solutions
Bezel LED Sequence	Bezel LED & Status LED Sequence		
White (3)	White (4)	External SD-RAM Error	External SD-RAM reading or writing was not properly performed. [Solution] Check that the following part is properly assembled and/or Harness are connected. [Relative Parts] CPU Circuit Board. If the error is not resolved, change the above related part or parts and calibrate the DBV-400 Unit.
White (3)	White (5)	EEPROM Error	EEPROM reading, writing and/or saving was not properly performed. [Solution] Perform the Sensor Calibration procedure. If the error is not resolved, check that the following part is properly assembled and/or Harness are connected. [Relative Parts] CPU Circuit Board. If the error is not resolved, change the above related part or parts and calibrate the DBV-400 Unit.
White (3)	White (6)	Downloading File Error	Downloading files does not proceed. [Solution] Select a file supported by the DBV-400 Unit.
White (3)	White (8)	I2C Access Error	While communicating with each device on the CPU Board, Sensors detect an abnormal operating condition. [Solution] Check that the following part is properly assembled and/or Harness are connected. Clean the following part. [Relative Parts] CPU Circuit Board. If the error is not resolved, change the above related part or parts and calibrate the DBV-400 Unit.
Red (3)	Red (1)	Stacker Motor Lock-Up	While operating the Stacker Motor, no pulse inputs occurred greater than the specified value. [Solution] Check that the following parts are properly assembled and/or Harness are connected. Clean or adjust the following parts and Sensors. [Relative Parts] Stacker Motor, Stacker Encoder. If the error is not resolved, change the above related part or parts and calibrate the DBV-400 Unit.
Red (3)	Red (2)	Pusher Mechanism Home Position Error	When stacking Banknotes, the Pusher Mechanism is not returning to the Home position. [Solution] Check that the following parts are properly assembled and/or Harness are connected. Clean or adjust the following parts and Sensors. [Relative Parts] Pusher Mechanism, Stacker Motor, Stacker Home Sensor, Stacker Motor Encoder. If the error is not resolved, change the above related part or parts and calibrate the DBV-400 Unit.
Red (3)	Red (3)	Banknote Jam (Cash Box)	When transporting a Banknote in to the Cash Box, the Sensors are not detecting a Banknote present condition when the time interval is too long, or the pulse number is greater than specified value for the function. [Solution] Remove Banknotes from the Cash Box. Check that the following parts are properly assembled and/or Harness are connected. Clean or adjust the following parts and Sensors. [Relative Parts] Exit Sensor, Pusher Mechanism, Stacker Motor, Stacker Home Sensor, Stacker Motor Encoder. If the error is not resolved, change the above related part or parts and calibrate the DBV-400 Unit.
Red (3)	Red (4)	Feed Motor Speed Error	While Initializing, pulse input interval is less than the specified value. [Solution] Remove Banknotes from the DBV-400 Unit. Check that the following parts are properly assembled and/or Harness are connected. Clean or adjust the following parts and Sensors. [Relative Parts] Feed Motor, Feed Motor Encoder. If the error is not resolved, change the above related part or parts and calibrate the DBV-400 Unit.
Red (3)	Red (5)	Feed Motor Lock-Up	While operating the Feed Motor, no pulse inputs occurred greater than the specified value. [Solution] Check that the following parts are properly assembled and/or Harness are connected. Clean or adjust the following parts and Sensors. [Relative Parts] Feed Motor, Feed Motor Encoder. If the error is not resolved, change the above related part or parts and calibrate the unit.
Red (3)	Red (8)	Fraud Detection	The Sensors detect Banknotes occurring with abnormal timing. [Solution] Check that the following parts are properly assembled and/or Harness are connected. Clean or adjust the following parts and Sensors. [Relative Parts] Entrance Sensor, Validation Sensor, Feed Motor and Feed Motor Encoder. If the error is not resolved, change the above related part or parts and calibrate the DBV-400 Unit.

Table A-4 LED Flash Error Codes (Continued)

Normal Operation	Performance Test	Error	Causes and Solutions
Bezel LED Sequence	Bezel LED & Status LED Sequence		
Magenta (3)	Magenta (1)	Cash Box Full	The Sensors detected that the Cash Box is full. [Solution] Remove Banknotes from the Cash Box. Check that the following parts are properly assembled and/or Harness are connected. Clean or adjust the following parts and Sensors. [Relative Parts] Pusher Mechanism, Stacker Motor, Stacker Home Sensor, Stacker Motor Encoder. If the error is not resolved, change the above related part or parts and calibrate the DBV-400 Unit.
Magenta (3)	Magenta (2)	Cash Box Removal	The Cash Box has been removed. [Solution] Firmly re-seat the Cash Box. Check that the following part is properly assembled and/or Harness are connected. Clean or adjust the following Sensor. [Relative Parts] Box Sensor. If the error is not resolved, change the above related part or parts and calibrate the DBV-400 Unit.
Magenta (3)	Magenta (3)	Banknote Jam (Transport Unit)	When transporting or returning a Banknote in the Transport Unit, the Sensors did not detect a Banknote present condition when the time interval was too long, or the pulse number is greater than specified value for the function. [Solution] Check that the following parts are properly assembled and/or Harness are connected. Clean or adjust the following parts and Sensors. [Relative Parts] Entrance Sensor, Validation Sensor, Exit Sensor, Feed Motor, Feed Motor Encoder. If the error is not resolved, change the above related part or parts and calibrate the DBV-400 Unit.

LED Flash Reject Code Conditions

Table A-5 lists the various LED Flash Reject Code causes and solutions for Banknotes.

Table A-5 LED Flash Reject Codes

Normal Operation	Performance Test	Error	Causes and Solutions
Bezel LED Sequence	Bezel LED & Status LED Sequence		
Yellow (3)	Yellow (2)	Magnification Error	The Sensors detected improper levels. [Solution] Clean the Banknote Path. Check that the Banknote is not damaged or exhibiting unfit conditions. Refer to "Banknote Fitness Requirements" on page 1-3 for unacceptable Banknote types. [Relative Parts] Validation Sensor. If the error is not resolved, change the above related part or parts and calibrate the DBV-400 Unit.
Yellow (3)	Yellow (3)	Denomination Error	The Sensor detected an abnormal Banknote Type. [Solution] Clean the Banknote Path. Check that the Banknote is not damaged or exhibiting unfit conditions. Refer to "Banknote Fitness Requirements" on page 1-3 for unacceptable Banknote types. [Relative Parts] Validation Sensor. If the error is not resolved, change the above related part or parts and calibrate the DBV-400 Unit.
Yellow (3)	Yellow (4)	Pattern Error	The Sensor detected an abnormal Banknote Type. [Solution] Clean the Banknote Path. Check that the Banknote is not damaged or exhibiting unfit conditions. Refer to "Banknote Fitness Requirements" on page 1-3 for unacceptable Banknote types. [Relative Parts] Validation Sensor. If the error is not resolved, change the above related part or parts and calibrate the DBV-400 Unit.
Yellow (3)	Yellow (5)	Photo Level Error	While transporting a Banknote, improper sensor levels were detected. [Solution] Clean the Banknote Path. Check that the Banknote is not damaged or exhibiting unfit conditions. Refer to "Banknote Fitness Requirements" on page 1-3 for unacceptable Banknote types. [Relative Parts] Validation Sensor. If the error is not resolved, change the above related part or parts and calibrate the DBV-400 Unit.
Yellow (3)	Yellow (6)	Banknote Length Abnormal	The Sensors detected the Banknote length was longer or shorter than the specified value. [Solution] Clean the Banknote Path. Check that the Banknote is not damaged or exhibiting unfit conditions. Refer to "Banknote Fitness Requirements" on page 1-3 for unacceptable Banknote types. [Relative Parts] Rollers, Validation Sensor. If the error is not resolved, change the above related part or parts and calibrate the DBV-400 Unit.
Yellow (3)	Yellow (7)	Pattern Error 1	The Sensor detected an improper Banknote pattern. [Solution] Clean the Banknote Path. Check that the Banknote is not damaged or exhibiting unfit conditions. Refer to "Banknote Fitness Requirements" on page 1-3 for unacceptable Banknote types. [Relative Parts] Validation Sensor. If the error is not resolved, change the above related part or parts and calibrate the DBV-400 Unit.
Yellow (3)	Yellow (8)	Invalid Banknote Error	The Sensors detected the Banknote as invalid. [Solution] Clean the Banknote Path. Check that the Banknote is not damaged or exhibiting unfit conditions. Refer to "Banknote Fitness Requirements" on page 1-3 for unacceptable Banknote types. [Relative Parts] Validation Sensor. If the error is not resolved, change the above related part or parts and calibrate the DBV-400 Unit.
Yellow (3)	Yellow (9)	Pattern Error 2	The Sensor detected an improper Banknote pattern. [Solution] Clean the Banknote Path. Check that the Banknote is not damaged or exhibiting unfit conditions. Refer to "Banknote Fitness Requirements" on page 1-3 for unacceptable Banknote types. [Relative Parts] Validation Sensor. If the error is not resolved, change the above related part or parts and calibrate the DBV-400 Unit.
Green (3)	Green (1)	Skewed Insertion Error	The Banknote has been inserted in an incorrect/crooked direction. [Solution] Insert a Banknote in the proper alignment. Clean the Banknote Path. [Relative Parts] Rollers. If the error is not resolved, change the above related part or parts.
Green (3)	Green (2)	Remaining Banknotes Returned	While Initializing, a Banknote was detected in the Unit. [Solution] Clean or adjust the following parts. [Relative Parts] Rollers, Validation Sensors. Entrance and Exit Sensors. If the error is not resolved, change the above related part or parts and calibrate the unit.

Table A-5 LED Flash Reject Codes (Continued)

Normal Operation	Performance Test	Error	Causes and Solutions
Bezel LED Sequence	Bezel LED & Status LED Sequence		
Green (3)	Green (3)	Transport Time-out Error	The Sensors detected improper movement of a Banknote. [Solution] Clean the Rollers, Banknote Path. [Relative Parts] Rollers, Sensors, Validation Sensor. If the error is not resolved, change the above related part or parts and calibrate the DBV-400 Unit.
Green (3)	Green (4)	Banknote Detection Error	The Sensors detected a Banknote with abnormal timing. [Solution] Clean debris from the Banknote Path. [Relative Parts] Entrance, Exit, Validation and Side Sensors. If the error is not resolved, change the above related part or parts and calibrate the DBV-400 Unit.
Green (3)	Green (5)	Inhibit Setting Abnormal	The Banknote has been inhibited by DIP Switch Setting or Host Command. [Solution] Check DIP Switch Block 1 Settings, refer to the Software Information Sheet for proper settings. Check Harness connections and communications. [Relative Parts] DIP Switch Block 1, Harnesses If the error is not resolved, change the above related part or parts.
Green (3)	Green (6)	Return Commanded	The Banknote was returned in response to a Host Command. [Solution] Check for proper communications with the Host computer. [Relative Parts] CPU. If the error is not resolved, change the above related part or parts and calibrate the DBV-400 unit.

Maintenance Equipment

This section provides product information for the DBV-400 Maintenance Equipment.

DBV-400 Maintenance Equipment

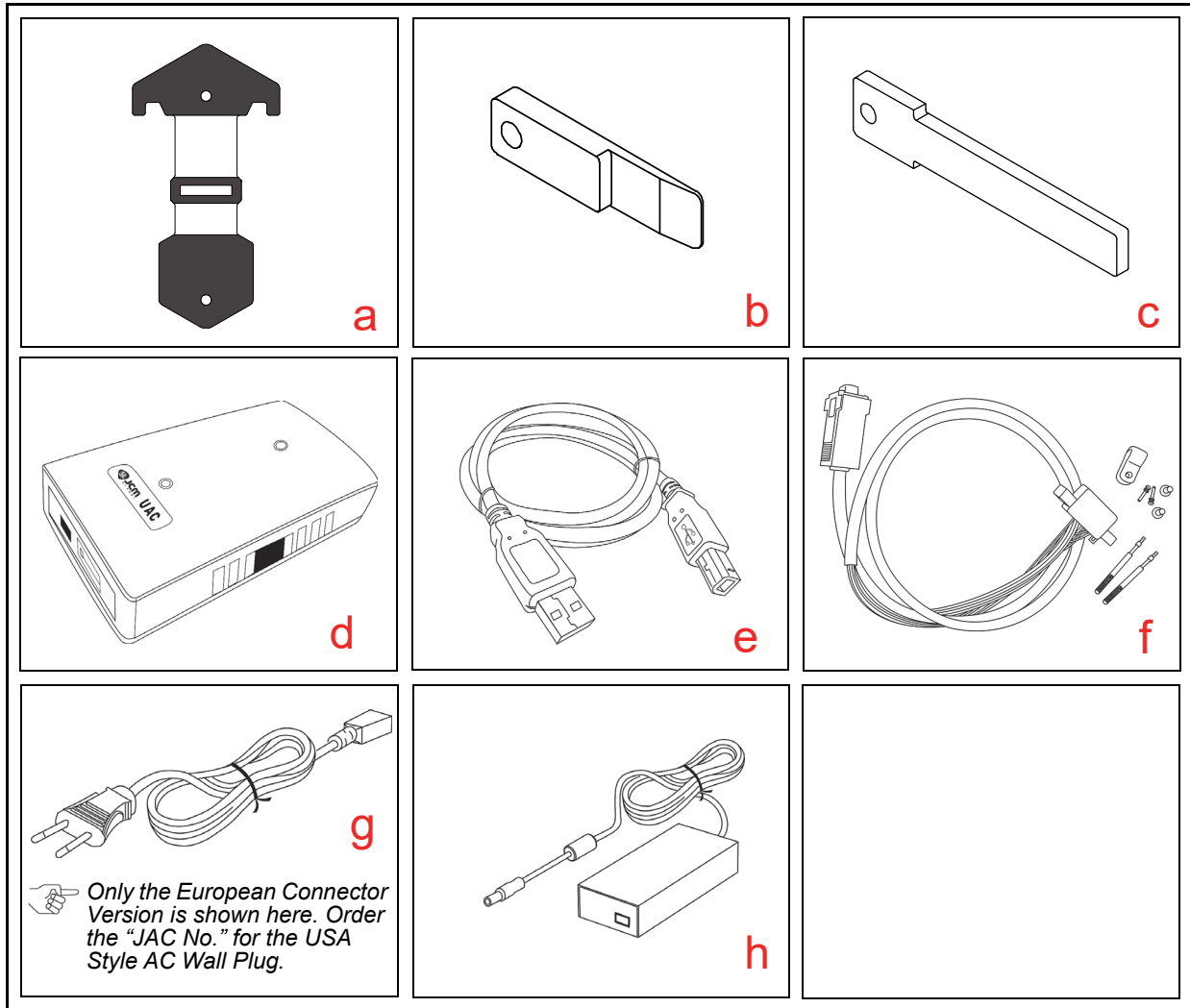

Figure A-1 Additional Maintenance Equipment Requirements

Table A-6 Additional Maintenance Equipment Parts List

Ltr.	EDP No.*	JAC No.	Description	Qty.	Remark
a	238678	← Use EDP#	Reference Paper (KS-095A)	1	
b	239641	← Use EDP#	Main Frame Assy. Disassembly Tool	8	
c	239642	← Use EDP#	Cash Box Disassembling Tool	8	
d	G00205	501-100218R	UAC Module	1	
e	G00230	400-100249R	UAC USB Cable	1	
f	GA0012	← Use EDP#	DBV-400 UAC Harness (ID003)	1	
g	G00213	302-100007RA	Power Cord (USA or Euro)	1	For AC Adapter
h	G00286	← Use G#	AC Power Adapter	1	For UAC

*. A Product EDP Number that begins with a "G" is a Product developed by JCM-E Germany.

Reference Paper Handling

All JCM Reference Paper should be handled as follows:

1. Do not allow the Reference Papers to endure high temperatures and/or high humidity environments.
2. Store unused Reference Papers in their original Shipping Carton to avoid exposing them to direct Sunlight and/or bright indoor light. Ensure that the Reference Papers being stored are not damaged as they are replaced into their shipping carton.
3. Do not use Reference Paper containing damaged areas that are worn, dirty, wrinkled, distorted and/or discolored.
4. Use new Reference Paper for every 400 Units being calibrated. Incorrect calibration errors may occur when using Reference Paper that has been used for calibrating more than 400 Units.

THIS PAGE INTENTIONALLY LEFT BLANK

DBV™ Series

DBV-400 Banknote Validator

Appendix B

B GLOSSARY

B

1 **Banknote Jam**

on occasion, wrinkled or damaged Banknotes become stuck within the mechanical area of the Validation Unit. This condition may occur due to acceptance of a severely degraded Banknote, or due to a feed error occurring in the Transport Path. Banknote Jams may be cleared by following instructions found in the Operations and Maintenance Manual ...2-10

2 **Bezel**

a removable Plastic Assembly attached to the front of the Banknote Insertion Slot of a DBV-400 Unit. It features a rectangular-shaped slot for easy insertion and retrieval of Banknotes. Bezels are available in different shapes and sizes in order to accommodate Banknotes of different widths and different stacking configurations ...1-2

C

3 **Calibration**

a process performed on electronic equipment which ensures that all circuits are properly aligned and operating at optimum levels. Calibration is accomplished using a software based program that checks and sets the operational reference levels for sensors. This helps to ensure that the Unit operates with the highest Banknote acceptance rate possible. Calibration is recommended whenever the CPU board or one of the Sensor Boards is replaced ...6-1

4 **Cash Box**

a container designed to collect and store the Banknotes accepted by the Validator ...1-2

5 **Checksum**

a numerical value assigned to a data file or block of data (usually expressed in Hexadecimal notation). Checksum values are used to verify that the contents of a data file are not corrupted in any way during transmission or encryption. The Checksum values of both the original and duplicate files are compared to each other. If the values do not match, it is recommended that the file be copied (uploaded) again until the Checksums do match ...6-5

6 **Country Code**

specific codes given to a country to identify its currency type ...1-2

D

7 **DIP Switch Block**

Dual In-line Package Switch - a mountable two-position slide switch containing up to 16 individual Switches per block assembly, located on a Printed Circuit Board (PCB) and set to an ON or OFF position. DIP Switches are often used in circuits where manual selection of operational changes, options, and features is desired ...2-1

E

8 **EEPROM**

Electrically Erasable Programmable Read-Only Memory. A form of non-volatile Read-Only Memory (ROM) that can be written to and erased via electronic signals without being removed from its Circuit Board housing. EEPROMs are often used to store system command instructions and reference data sets that are accessed frequently, or when the equipment is first powered up ...6-10, A-4

H

9 **Host Machine**

a generic term for any electronic cabinet, equipment or platform where a DBV-400 Unit will be installed. The Host Machine supplies both the power and the communications interface necessary for proper operation of the DBV-400 Unit ...A-3

J

10 **JCM Tool Suite Standard Edition**

a PC application software program that includes sub-routine programs for Downloading a File, Calibrating Sensors, examining Performance Metrics, testing Acceptor functions, Enabling and disabling the ICB feature, and viewing an image of the last Banknote accepted ...6-1

L

11 **LED**

an acronym for Light Emitting Diode. An LED is Semiconductor Device which (when turned on) emits a signal output in the visible light range. Available in a variety of colors, LEDs are cost-effective and are commonly used as Indicator Lights in a variety of equipment and devices. LEDs are also available in the invisible light range (e.g., ultraviolet, near-infrared), making them useful as operational indicators for a variety of electronic equipment and applications, such as Banknote Validation Circuits in the Validator Unit ...1-6, 6-8

O

12 **Optical Sensor**

a Photo Sensitive Device and LED combination which generates a signal of varying amplitude in response to changes or blockage of the amount of light striking the sensor surface. Optical Sensors are well-suited for detecting timing and movement events ...1-6

P

13 **Pictograph**

small internationally recognized safety and attention symbols placed to the left of Notes, Cautions and Warnings throughout a JCM Maintenance Manual ...1-1

14 **Precautions**

special instructions and warnings that appear in JCM Maintenance Manuals. Precautions are intended to promote personal safety and prevent damage to equipment when working with the applicable JCM Product ...1-2

R

15 **Reference paper**

specially coated/colored paper strips that are inserted into a Banknote Validator when performing Validator Unit Calibration. Reference Paper is used to help set minimum and maximum threshold detection levels when adjusting the photo-optical Sensors in the unit for optimum performance ...6-5

16 **RS232C**

a common Serial Data communication standard Protocol ...2-4

S

17 **Special Notes**

notation within JCM Maintenance Manuals that alerts the reader to specific information that can affect operation of the Unit. Notations often appear throughout the manual, and are identified by the pictograph icon. Special Notes are always written in italic text ...1-1

T

18 **TTL**

an acronym for Transistor to Transistor Logic levels ...2-5

U**19 USB**

an acronym for Universal Serial Bus. The USB protocol is a widely used serial-based communications data bus which allows a large number of peripheral devices to communicate with a host controller, and is commonly found on nearly all personal computers built today. The DBV-400 features a USB interface, allowing the user to download data files into flash memory quickly and easily from a PC ...2-9

V**20 Validator**

Electronic equipment that accepts and validates the authenticity of Banknotes used in automated cash transactions and vending operations. Validation involves the process of drawing a Banknote into the Unit, and then reading and determining the authenticity of the Banknote based on a comparison of data received from magnetic sensors, optical sensors or both to a set of reference data stored in memory ...1-1



a
RoHS
Compliant
Product



JCM

G L O B A L



Contains
RoHS
Compliant
Components

Issue #4107-SME-01-01